

PILOT OPERATED CHECK VALVE

MCDN-060-TBNS

DOUBLE ACTING
TWO FLANGED PORTS

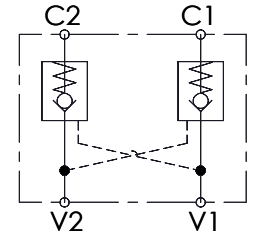
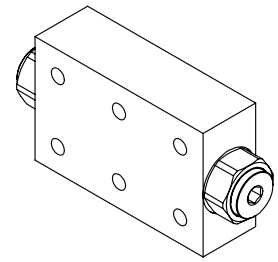
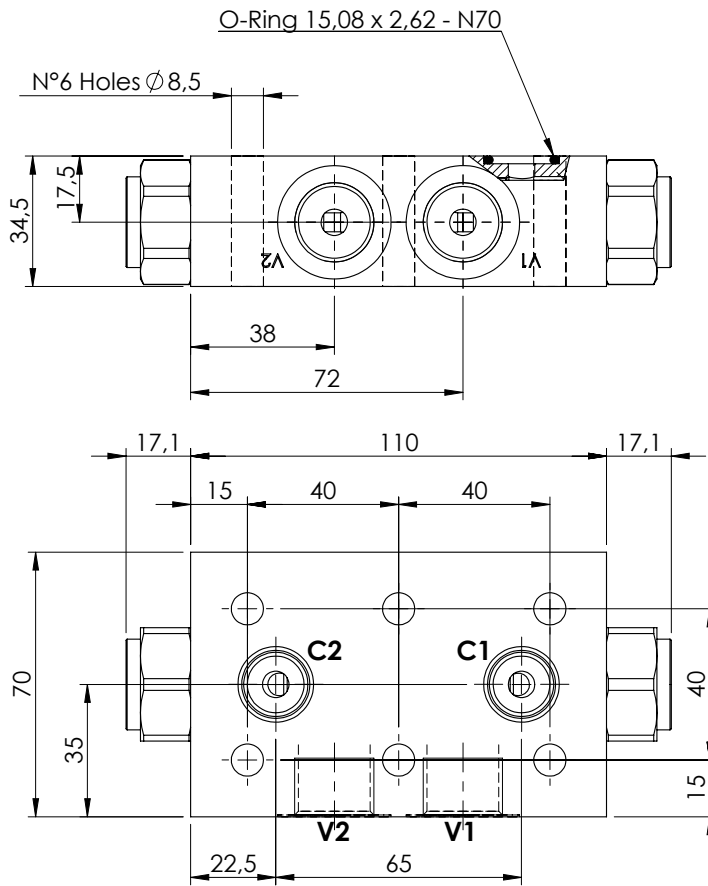

SPECIFICATIONS

Max. operating pressure:	350 bar
Rated flow:	60 l/min
Manifold:	Aluminium
Weight:	0,90 kg

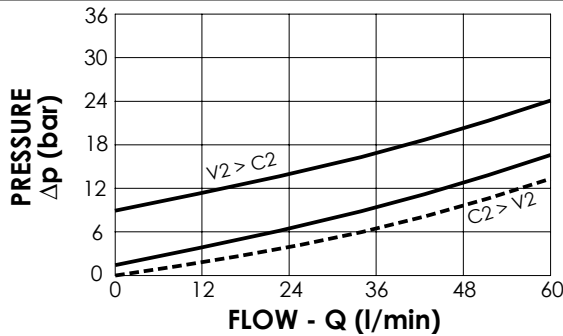

ORDERING CODES

Quick code	Description	Main ports size	Pilot ratio	Cracking pressure (bar)	O-Ring on pilot piston
MC000029	MCDN-060-TBNS-03-G12-N001	V1,V2:G 1/2" C1,C2: $\varnothing 7$	3:1	1	NO
MC000027	MCDN-060-TBNS-03-G12-N008	V1,V2:G 1/2" C1,C2: $\varnothing 7$	3:1	8	NO
MC000028	MCDN-060-TBNC-03-G12-N008	V1,V2:G 1/2" C1,C2: $\varnothing 7$	3:1	8	YES
MC000026	MCDN-060-TBNS-06-G12-N001	V1,V2:G 1/2" C1,C2: $\varnothing 7$	6:1	1	NO
MC000025	MCDN-060-TBNS-06-G12-N008	V1,V2:G 1/2" C1,C2: $\varnothing 7$	6:1	8	NO
MC000022	MCDN-060-TBNC-06-G12-N008	V1,V2:G 1/2" C1,C2: $\varnothing 7$	6:1	8	YES