

PILOT OPERATED CHECK VALVE

MCSN-020-TLRC

**SINGLE ACTING
MANUAL SHUT OFF
RIGHT VERSION**

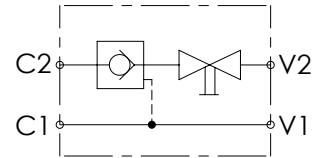
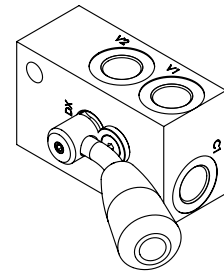
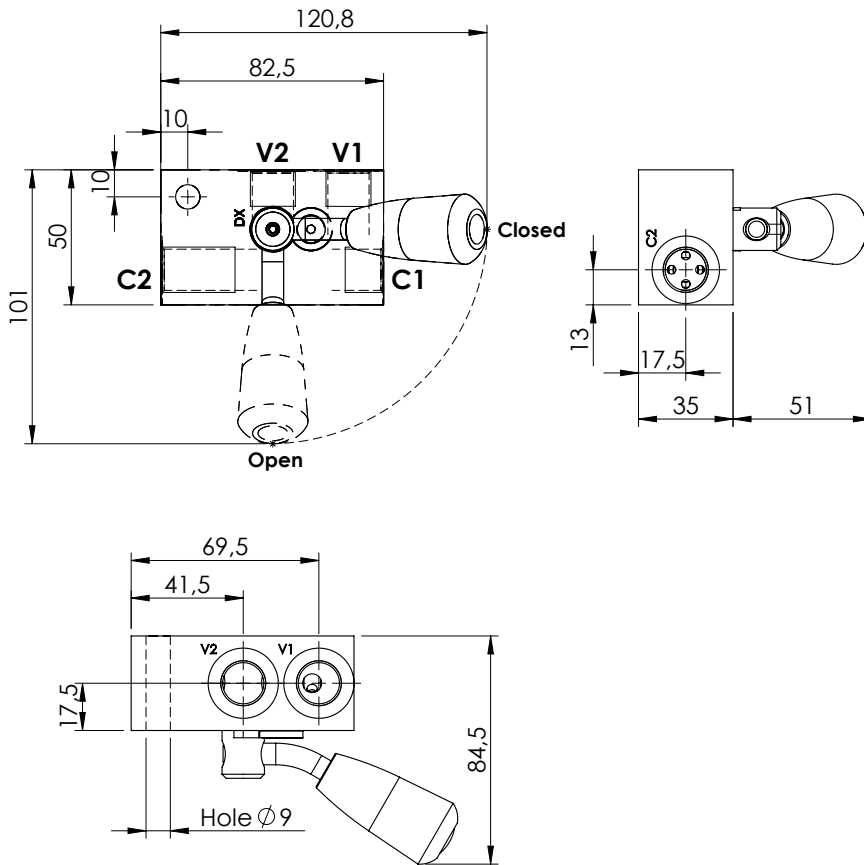

SPECIFICATIONS

Max. operating pressure:	350 bar
Rated flow:	20 l/min
Manifold:	Aluminium
Weight:	0,46 kg

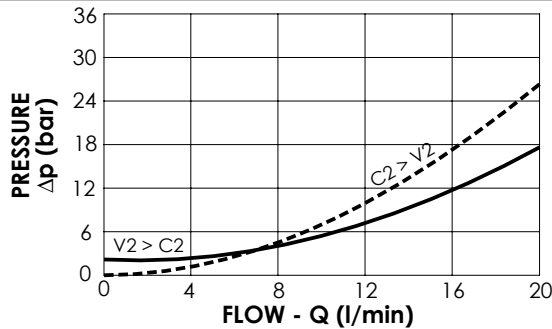

ORDERING CODES

Quick code	Description	Main ports size	Pilot ratio	Cracking pressure (bar)	O-Ring on pilot piston
MC000061	MCSN-020-TLRC-05-G38-N002	V1,V2,C1,C2 : G 3/8"	5:1	2	YES