



Pressure Reducing Valves

Section 2

SECTION 2



PRESSURE REDUCING VALVES

Hydraulic scheme	Valve description	Valve type	Rated flow (l/min)	Max. pressure (bar)	Installation	Main port size or cavity type	Page
	CPRL-007-DNNR	Direct acting, reducing and relieving	5	350	Cartridge	VP000016	2.01. 010
	CPRL-030-DNNR	Direct acting, reducing and relieving	30	350	Cartridge	SAE-10-3N	2.01. 020
	KPRL-030-DNNR	Direct acting, reducing and relieving	30	250	In line	G3/8"	2.02. 050
	CPRL-060-PNNR	Pilot operated, reducing and relieving	60	350	Cartridge	SAE-10-3N	2.02. 030
	CPRL-140-PNNR	Pilot operated, reducing and relieving	140	350	Cartridge	SAE-12-3N	2.02. 040
	KPRL-060-DNNR	Pilot operated, reducing and relieving	60	250	In line	G3/8"	2.02. 050
	CPRR-060-PNNR	Pilot operated, reducing	60	350	Cartridge	SAE-10-3N	2.03. 060
	CPRR-140-PNNR	Pilot operated, reducing	140	350	Cartridge	SAE-12-3N	2.03. 070
	KPRR-140-PNNR	Pilot operated, reducing	140	350	In line	G1/2"	2.03. 080

PRESSURE REDUCING AND RELIEVING

CPRL-007-DNNR

**DIRECT ACTING
SPOOL TYPE**

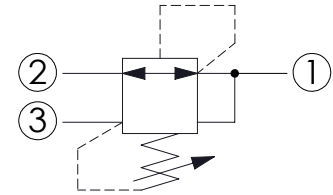
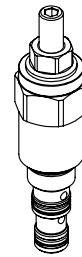
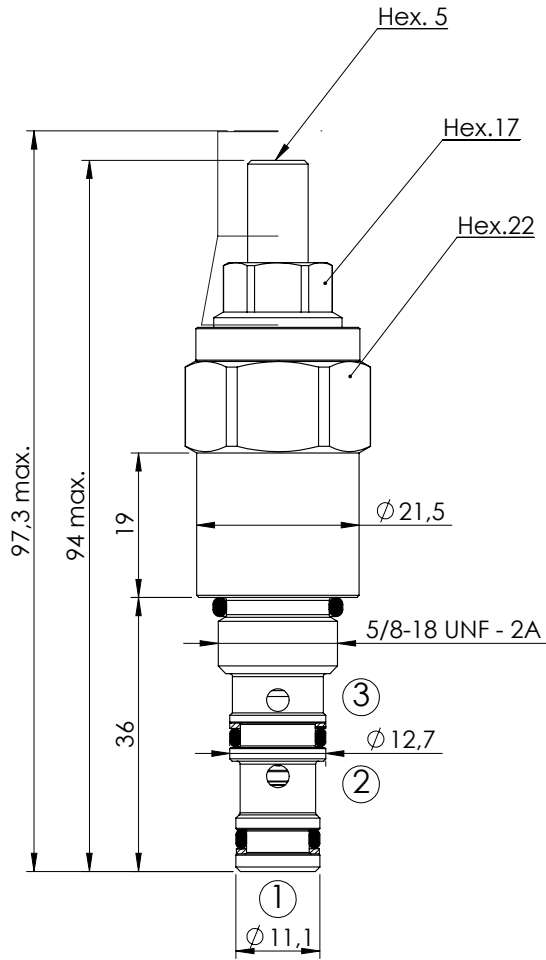

SPECIFICATIONS

Max. operating pressure:	350 bar
Rated flow:	5 l/min
Cavity:	VP000016
Weight:	0,14 kg
Installation torque:	25 - 30 Nm
Leakage:	35 cm ³ @ 50 bar
Seal kit:	RC700016

SEALING CAP

Ordering code:
AT000020

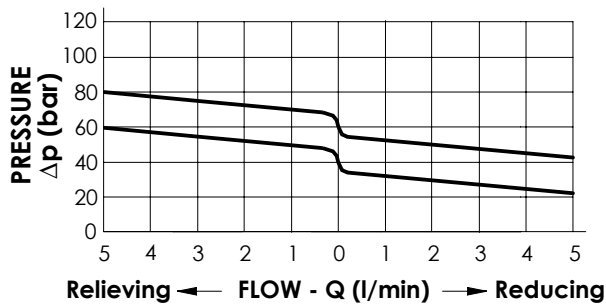

ORDERING CODES

Quick code	Description	Standard setting (bar)	Adjust. range (bar)	Pressure increase (bar/turn)	
CR000001	CPRL-007-DNNR-HN-016-N060	40	10-60	6	
CR000025	CPRL-007-DNNR-HN-016-N085	60	25-85	9	

PRESSURE REDUCING AND RELIEVING

CPRL-030-DNNR

**DIRECT ACTING
SPOOL TYPE**

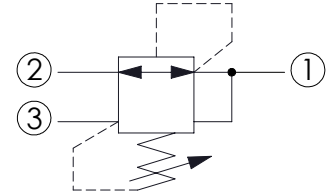
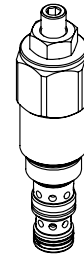
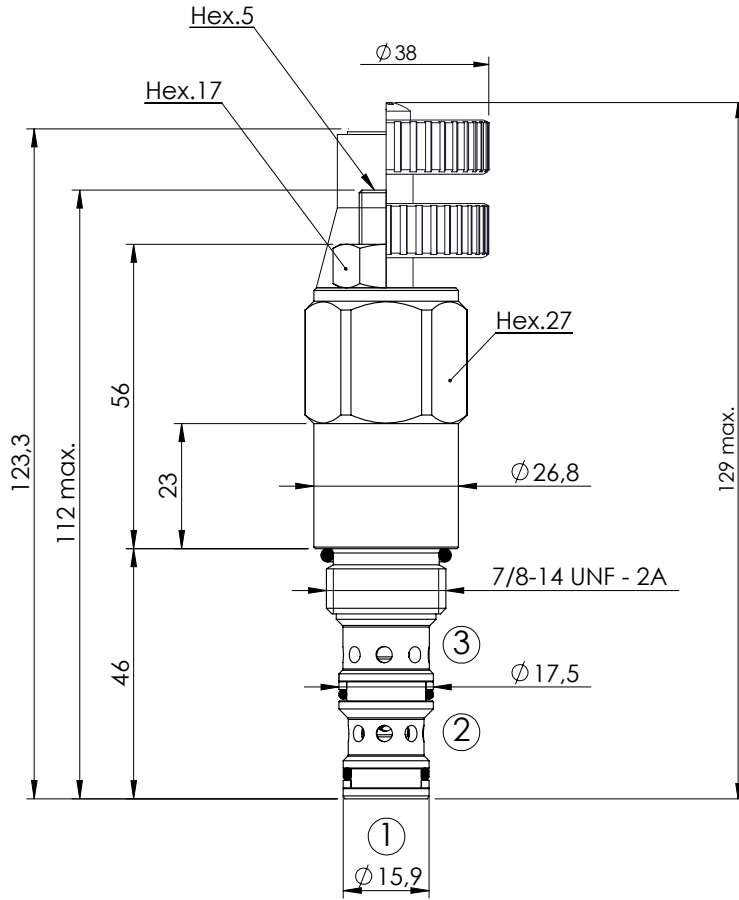

SPECIFICATIONS

Max. operating pressure:	350 bar
Rated flow:	30 l/min
Cavity:	SAE-10-3N
Weight:	0,28 kg
Installation torque:	50 - 55 Nm
Leakage:	50 cm ³ @ 50 bar
Seal kit:	RA700092

SEALING CAP

Ordering code:

AT000021



OPTIONS

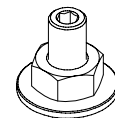

Adjustment
with Screw

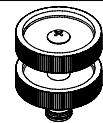

Adjustment
with Handknob

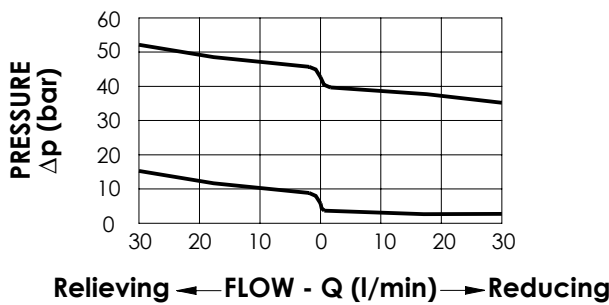

ORDERING CODES

Quick code	Description	Standard setting (bar)	Adjust. range (bar)	Pressure increase (bar/turn)	Options
CR000002	CPRL-030-DNNR-HN-S10-N050	35	10-50	7	Adjustment with Screw
CR000008	CPRL-030-DNNR-VN-S10-N050	35	10-50	7	Adjustment with Handknob
CR000011	CPRL-030-DNNR-HN-S10-N015	5	1.5-15	1	Adjustment with Screw
CR000012	CPRL-030-DNNR-VN-S10-N015	5	1.5-15	1	Adjustment with Handknob

PRESSURE REDUCING AND RELIEVING

CPRL-060-PNNR

**PILOT OPERATED
SPOOL TYPE**

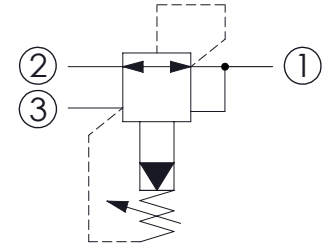
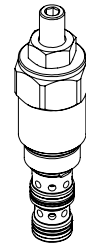
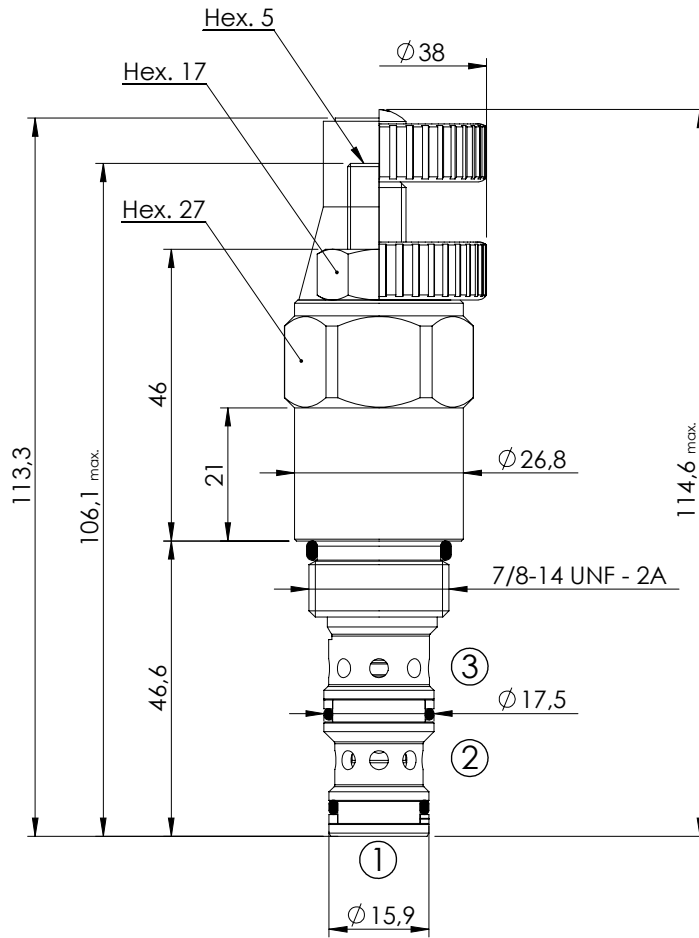

SPECIFICATIONS

Max. operating pressure:	350 bar
Rated flow:	60 l/min
Cavity:	SAE-10-3N
Weight:	0,26 kg
Installation torque:	50 - 55 Nm
Seal kit:	RA700092

SEALING CAP

Ordering code:
AT000021



OPTIONS

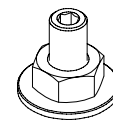

Adjustment
with Screw

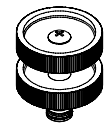

Adjustment
with Handknob

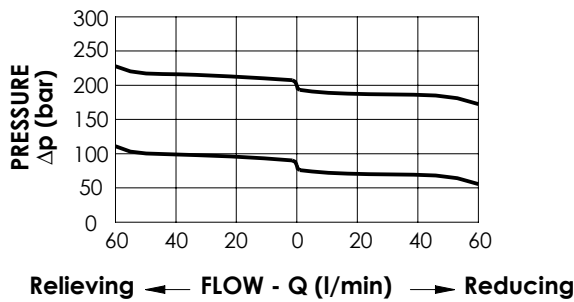

ORDERING CODES

Quick code	Description	Standard setting (bar)	Adjust. range (bar)	Pressure increase (bar/turn)	Options
CR000006	CPRL-060-PNNR-HN-S10-N300	200	70-350	114	Adjustment with Screw
CR000007	CPRL-060-PNNR-VN-S10-N300	200	70-350	114	Adjustment with Handknob
CR000009	CPRL-060-PNNR-HN-S10-N100	80	20-110	37	Adjustment with Screw
CR000010	CPRL-060-PNNR-VN-S10-N100	80	20-110	37	Adjustment with Handknob

PRESSURE REDUCING AND RELIEVING

CPRL-140-PNNR

**PILOT OPERATED
SPOOL TYPE**

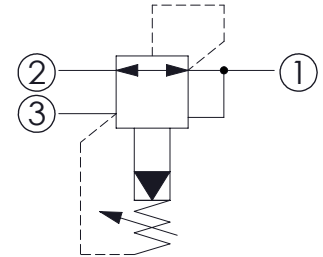
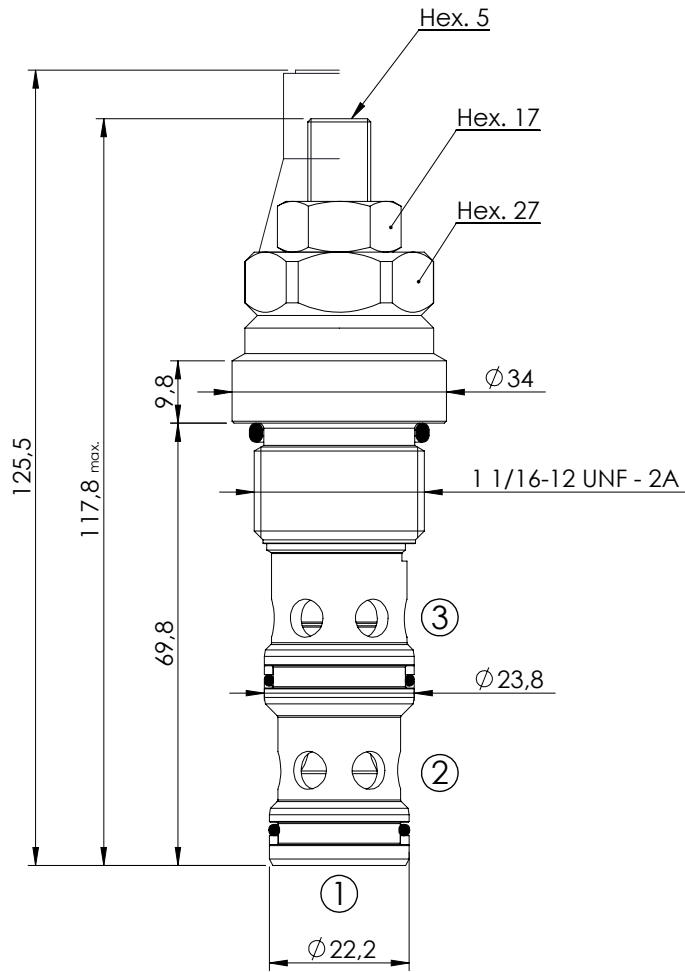

SPECIFICATIONS

Max. operating pressure:	350 bar
Rated flow:	140 l/min
Cavity:	SAE-12-3N
Weight:	0,34 kg
Installation torque:	80 - 92 Nm
Seal kit:	RA700093

SEALING CAP

Ordering code:
AT000021



OPTIONS

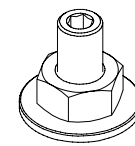

Adjustment
with Screw

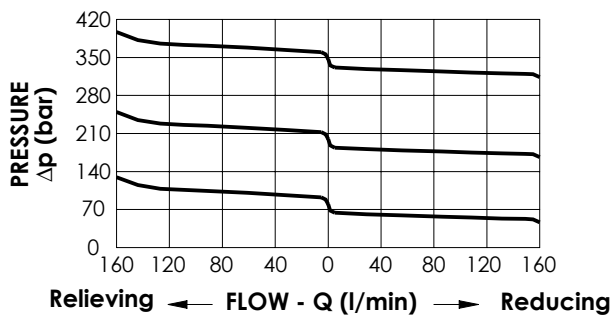

ORDERING CODES

Quick code	Description	Standard setting (bar)	Adjust. range (bar)	Pressure increase (bar/turn)	Options
CR000020	CPRL-140-PNNR-HN-S12-N350	300	140-350	114	Adjustment with Screw
CR000019	CPRL-140-PNNR-HN-S12-N200	200	70-250	69	Adjustment with Screw
CR000018	CPRL-140-PNNR-HN-S12-N100	100	10-140	37	Adjustment with Screw

PRESSURE REDUCING AND RELIEVING IN BODY

KPRL-030-DNNR

**DIRECT/PILOT ACTING
SPOOL TYPE**

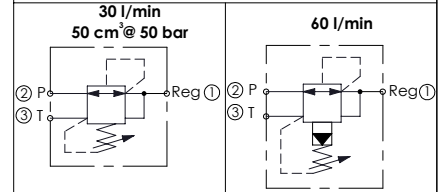
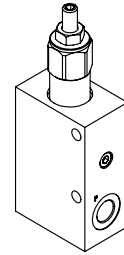
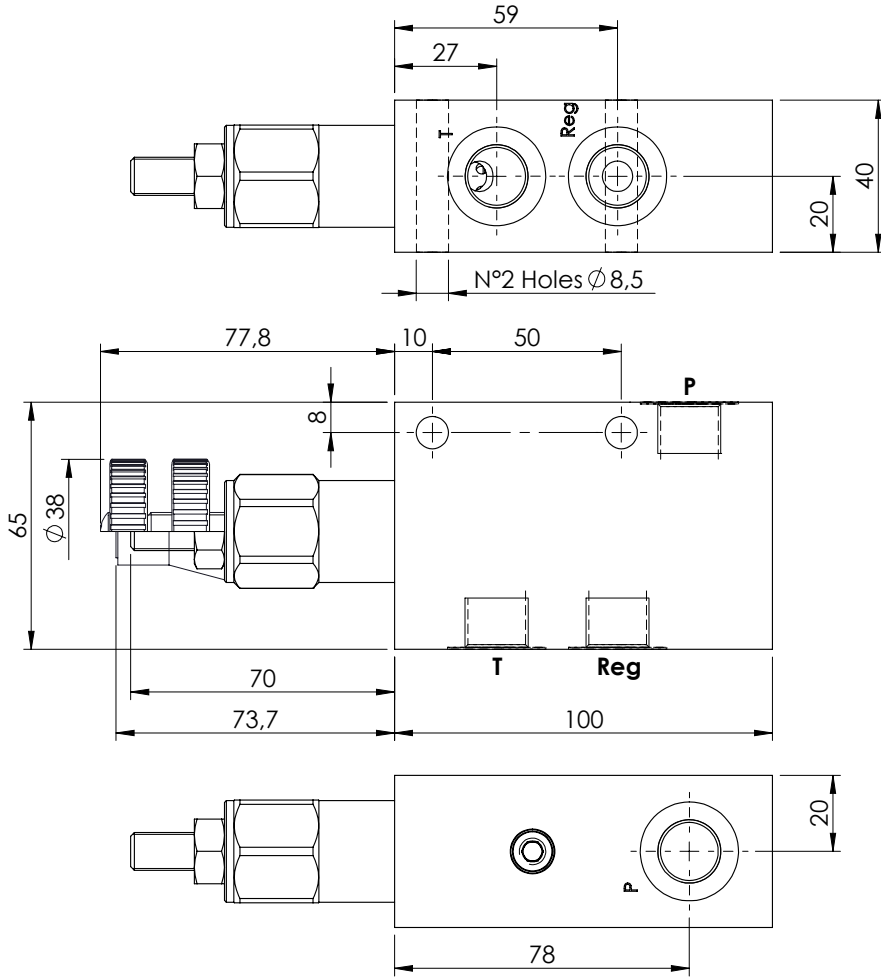

KR00011
KR00012
KR00013
KR00014

KR00015
KR00016

SPECIFICATIONS

Max. operating pressure:	250 bar
Rated flow:	30 l/min - 60 l/min
Cavity:	SAE-10-3N
Weight:	0,87 Kg
Leakage direct:	50cm³@ 50 bar
Manifold:	Aluminium

SEALING CAP

Ordering code:
AT000021



OPTIONS

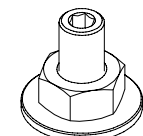

Adjustment with Screw

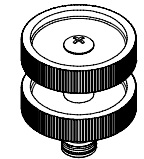

Adjustment with Handknob

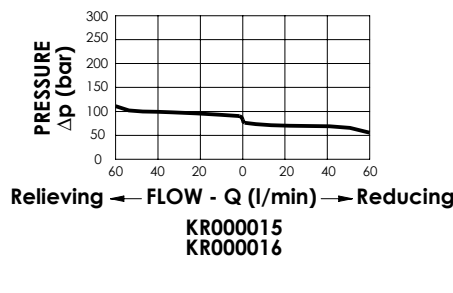
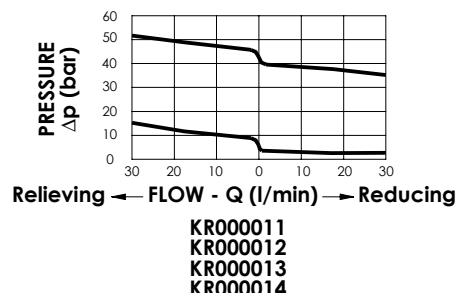

ORDERING CODES

Quick code	Description	Ports	Standard setting (bar)	Adjust. range (bar)	Pressure increase (bar/turn)	Options
KR00011	KPRL-030-DNNR-HN-G38-N250	G 3/8"	5	1.5-15	1.6	Adjustment with Screw
KR00012	KPRL-030-DNNR-VN-G38-N250	G 3/8"	5	1.5-15	1.6	Adjustment with Handknob
KR00013	KPRL-030-DNNR-HN-G38-N250	G 3/8"	35	10-50	7	Adjustment with Screw
KR00014	KPRL-030-DNNR-VN-G38-N250	G 3/8"	35	10-50	7	Adjustment with Handknob
KR00015	KPRL-060-PNNR-HN-G38-N250	G 3/8"	80	20-110	37	Adjustment with Screw
KR00016	KPRL-060-PNNR-VN-G38-N250	G 3/8"	80	20-110	37	Adjustment with Handknob

PRESSURE REDUCING

CPRR-060-PNNR

**PILOT OPERATED
SPOOL TYPE**

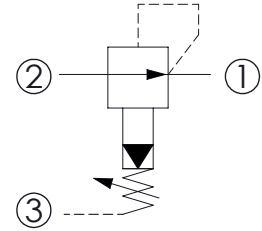
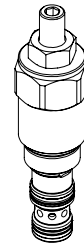
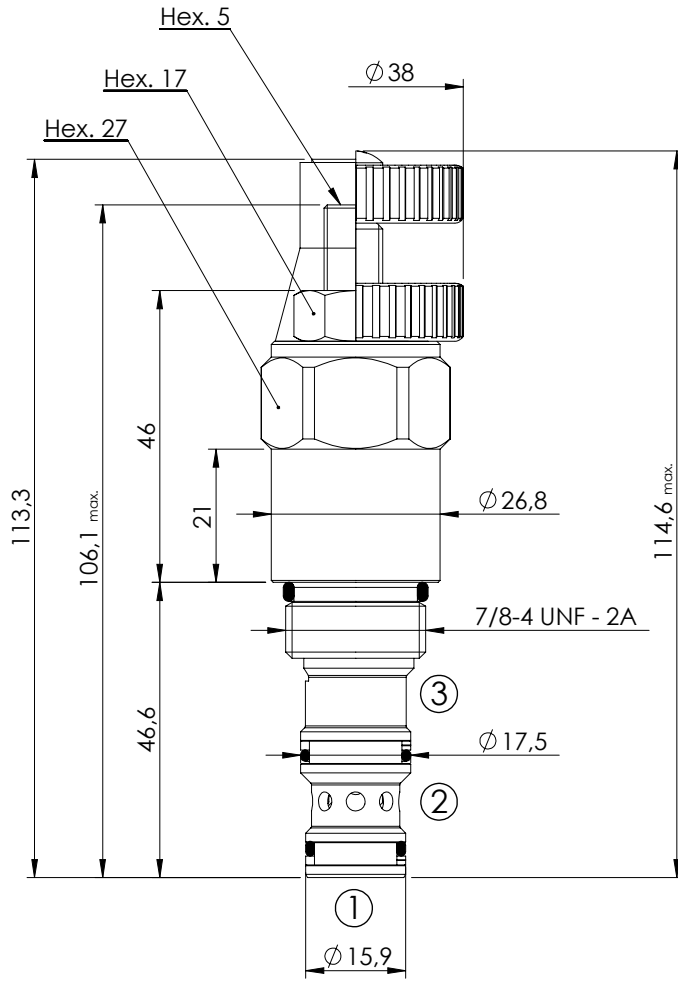

SPECIFICATIONS

Max. operating pressure:	350 bar
Rated flow:	60 l/min
Cavity:	SAE-10-3N
Weight:	0,26 kg
Installation torque:	45 - 60 Nm
Seal kit:	RA700092

SEALING CAP

Ordering code:
AT000021



OPTIONS

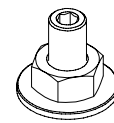

Adjustment
with Screw

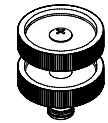

Adjustment
with Handknob

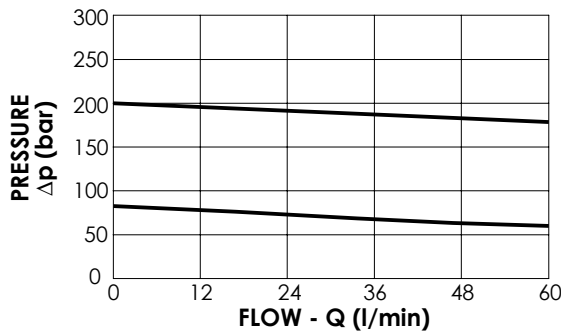

ORDERING CODES

Quick code	Description	Standard setting (bar)	Adjust. range (bar)	Pressure increase (bar/turn)	Options
CR000022	CPRR-060-PNNR-HN-S10-N300	200	70-350	114	Adjustment with Screw
CR000023	CPRR-060-PNNR-VN-S10-N300	200	70-350	114	Adjustment with Handknob
CR000024	CPRR-060-PNNR-HN-S10-N100	80	20-110	37	Adjustment with Screw
CR000021	CPRR-060-PNNR-VN-S10-N100	80	20-110	37	Adjustment with Handknob

PRESSURE REDUCING

CPRR-140-PNNR

**PILOT OPERATED
SPOOL TYPE**

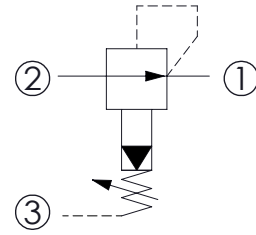
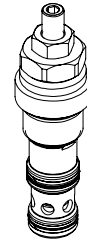
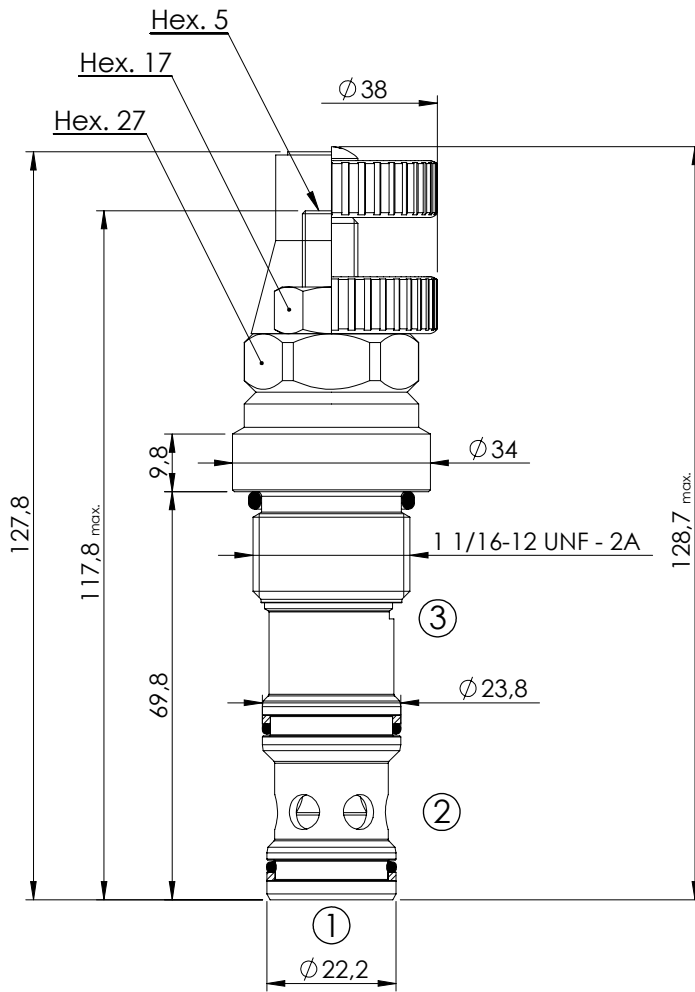

SPECIFICATIONS

Max. operating pressure:	350 bar
Rated flow:	140 l/min
Cavity:	SAE-12-3N
Weight:	0,35 kg
Installation torque:	80 - 92 Nm
Seal kit:	RA700093

SEALING CAP

Ordering code:
AT000021



OPTIONS

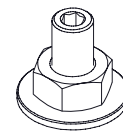

Adjustment
with Screw

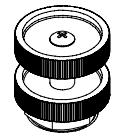

Handknob
and locknut

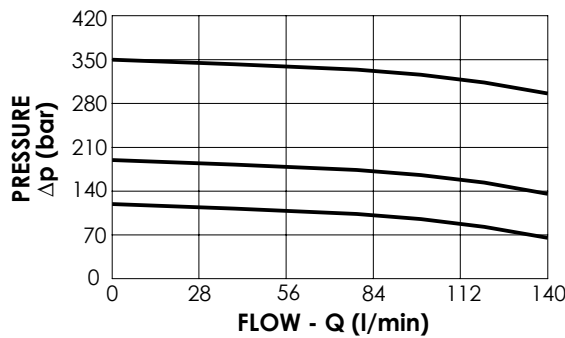

ORDERING CODES

Quick code	Description	Standard setting (bar)	Adjust. range (bar)	Pressure increase (bar/turn)	Options
CR000017	CPRR-140-PNNR-HN-S12-N350	300	140-350	114	Adjustment with Screw
CR000030	CPRR-140-PNNR-VN-S12-N350	300	140-350	114	Adjustment with Handknob
CR000016	CPRR-140-PNNR-HN-S12-N200	200	70-210	69	Adjustment with Screw
CR000027	CPRR-140-PNNR-VN-S12-N200	200	70-210	69	Adjustment with Handknob
CR000015	CPRR-140-PNNR-HN-S12-N100	100	10-120	37	Adjustment with Screw
CR000031	CPRR-140-PNNR-VN-S12-N100	100	10-120	37	Adjustment with Handknob

PRESSURE REDUCING IN BODY

KPRR-140-PNNR

**PILOT OPERATED
SPOOL TYPE**

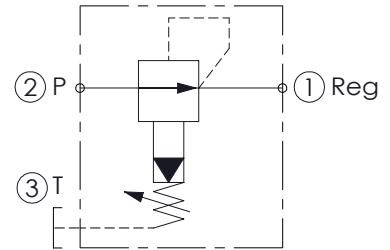
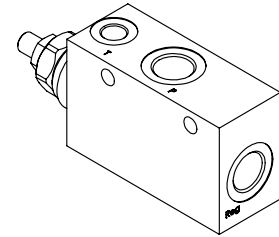
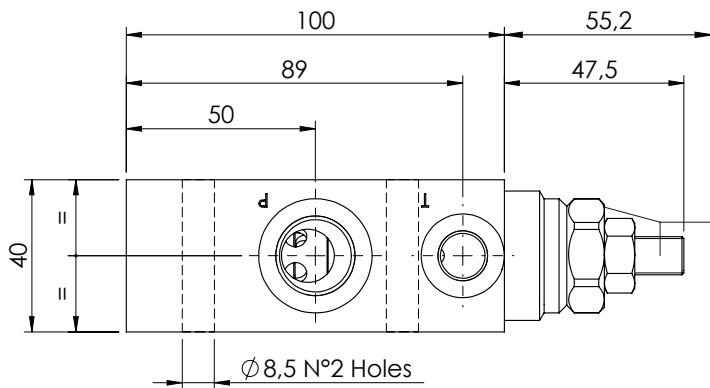
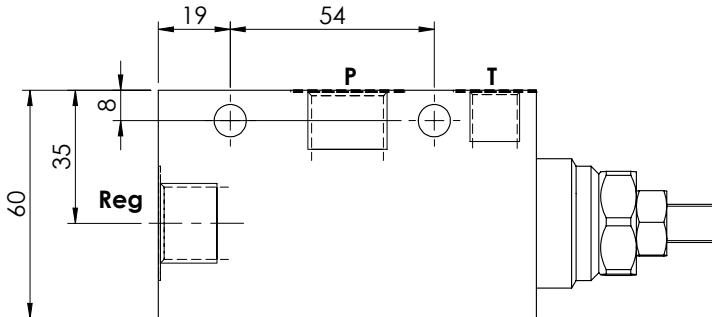

SPECIFICATIONS

Max. operating pressure:	250 bar
Rated flow:	140 l/min
Cavity:	SAE-12-3N
Weight:	0.8 kg
Manifold:	Aluminium

SEALING CAP

Ordering code:
AT000021

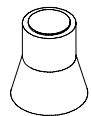

OPTIONS

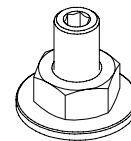

**Adjustment
with Screw**

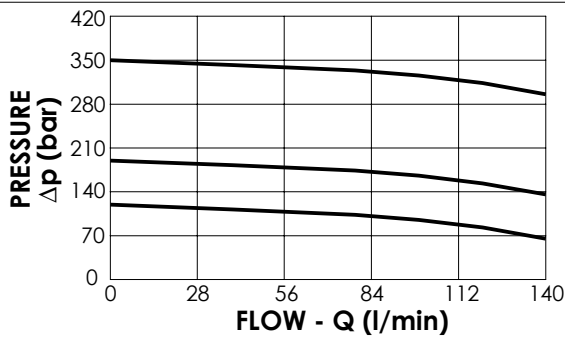

ORDERING CODES

Quick code	Description	Ports	Standard setting (bar)	Adjust. range (bar)	Pressure increase (bar/turn)	Options
KR000017	KPRR-140-PNNR-HN-G12-N350	P-Reg : G 1/2" T : G 1/4"	300	140-350	114	Adjustment with Screw
KR000019	KPRR-140-PNNR-HN-G12-N200	P-Reg : G 1/2" T : G 1/4"	200	70-210	69	Adjustment with Screw
KR000018	KPRR-140-PNNR-HN-G12-N100	P-Reg : G 1/2" T : G 1/4"	100	10-120	37	Adjustment with Screw