

RELIEF VALVE

CPLN-010-DHNA

**DIRECT ACTING
HARDENED SEAT**

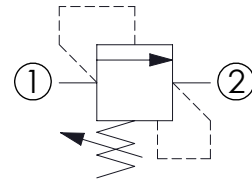
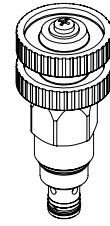
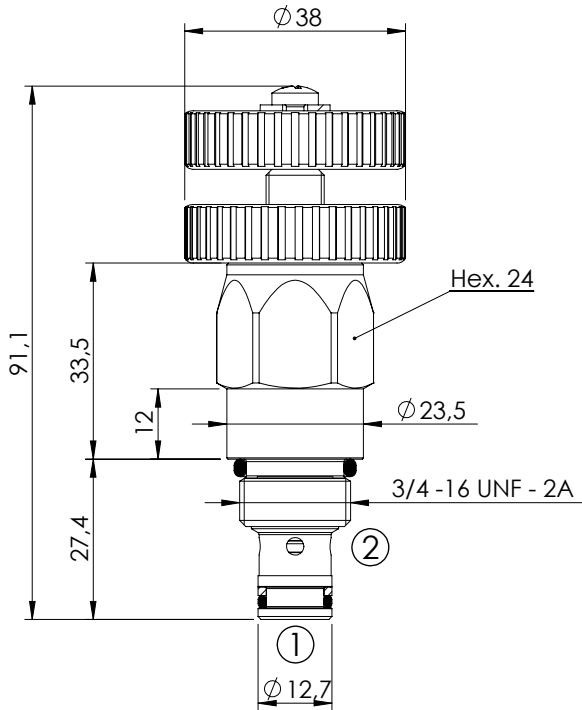

SPECIFICATIONS

Max. operating pressure:	350 bar
Rated flow:	3 l/min
Cavity:	SAE-08-2N
Weight:	0,18 kg

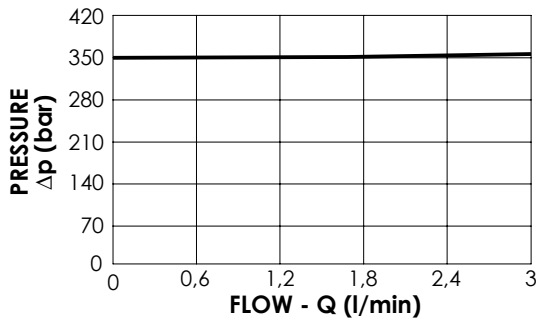

NOTES

Installation torque:	45 - 50 Nm
Seal kit:	RA700081

ORDERING CODES

Quick code	Description	Standard setting (bar, cracking pressure)	Adjustment range (bar)	Pressure increase (bar/turn)
CP000172	CPLN-010-DHNA-VN-S08-N350	350	20-350	83