

RELIEF VALVE

CPLT-080-DHNA

**DIRECT ACTING
STABILIZED PISTON
COMPENSATED**

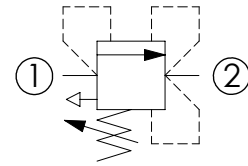
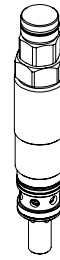
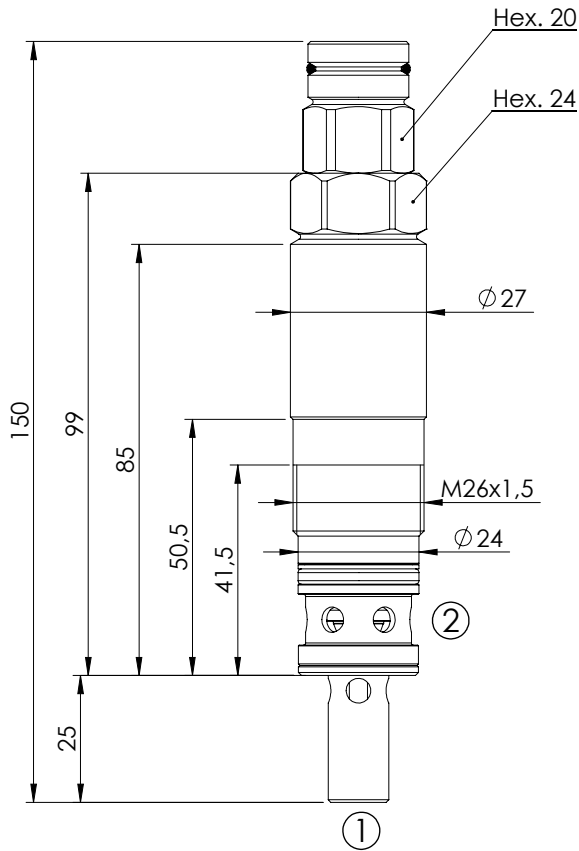

SPECIFICATIONS

Max. operating pressure:	420 bar
Rated flow:	80 l/min
Cavity:	VP000086
Weight:	0,41 kg

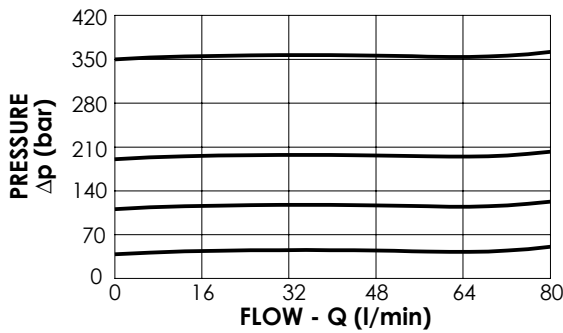

NOTES

Installation torque:	83 - 92 Nm
Seal kit:	RC700086

ORDERING CODES

Quick code	Description	Standard setting (bar, Q=5 l/min)	Adjustment range (bar)	Pressure increase (bar/turn)
CP000181	CPLT-080-DHNA-HN-086-N420	350	150-420	53
CP000130	CPLT-080-DHNA-HN-086-N350	350	100-350	42
CP000142	CPLT-080-DHNA-HN-086-N200	200	60-210	24
CP000143	CPLT-080-DHNA-HN-086-N100	100	25-100	13
CP000144	CPLT-080-DHNA-HN-086-N050	50	5-50	9