

RELIEF VALVE

CPLN-040-DHGD

DIFFERENTIAL AREA
POPPET TYPE

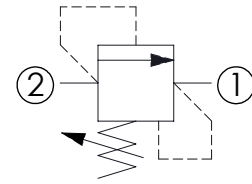
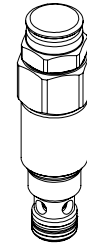
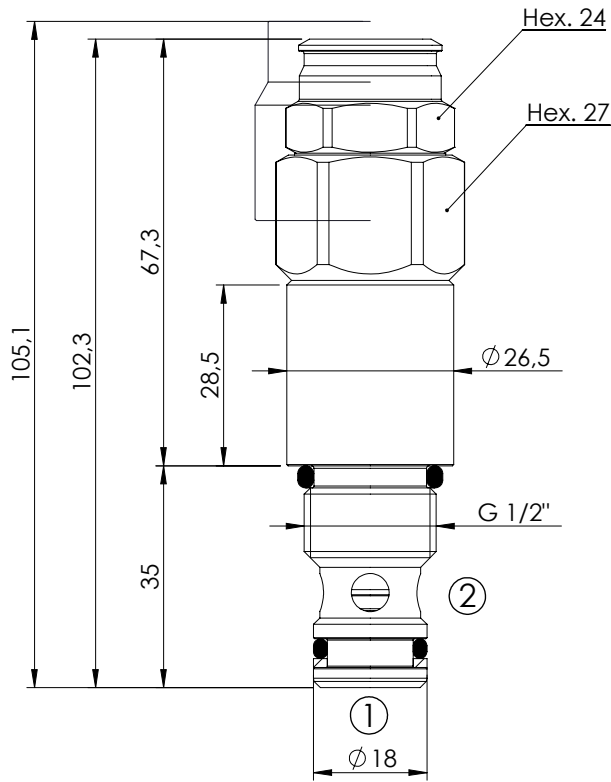

SPECIFICATIONS

Max. operating pressure:	350 bar
Rated flow:	40 l/min
Cavity:	VP000080
Weight:	0,31 kg

SEALING CAP

Ordering code:
PT000258

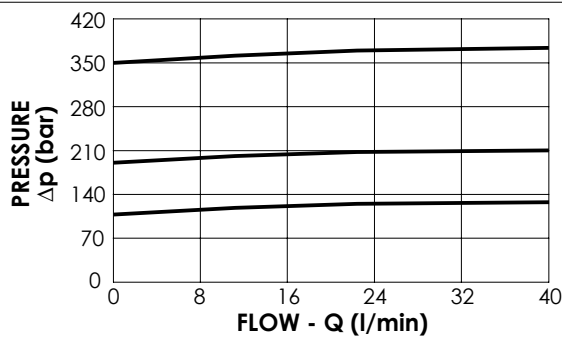
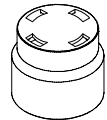

NOTES

Installation torque:	95 - 105 Nm
Seal kit:	RC900080

ORDERING CODES

Quick code	Description	Standard setting (bar, Q=5 l/min)	Adjustment range (bar)	Pressure increase (bar/turn)
CP000036	CPLN-040-DHGD-HN-080-N350	350	100-350	119
CP000088	CPLN-040-DHGD-HN-080-N200	200	50-210	63
CP000223	CPLN-040-DHGD-HN-080-N100	100	30-100	30