

SEQUENCE VALVE IN BODY

KPST-030-DPNA

**DIRECT ACTING
STABILIZED PISTON
COMPENSATED**

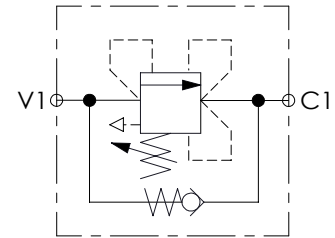
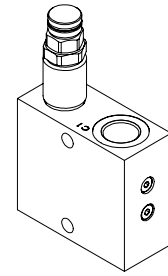
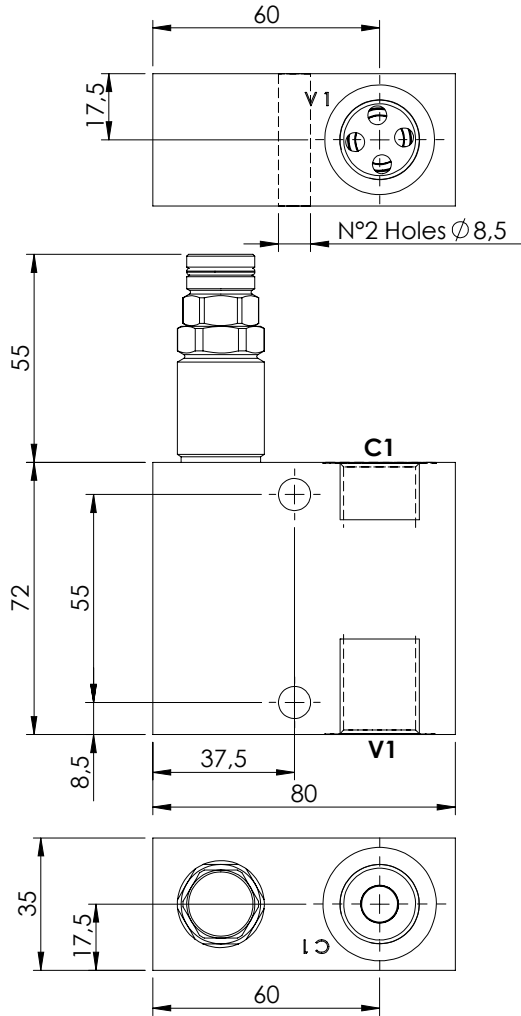

SPECIFICATIONS

Max. operating pressure:	350 bar
Rated flow:	30 l/min
Manifold:	Aluminium
Weight:	0,67 kg

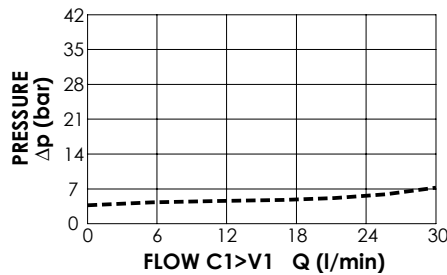
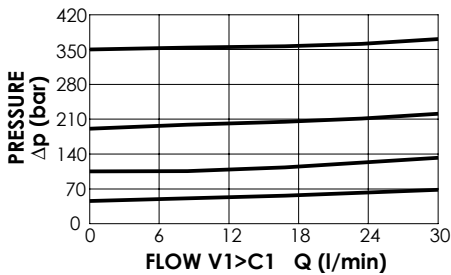

ORDERING CODES

Quick code	Description	Main ports size	Standard setting (bar, Q=5 l/min)	Adjustm. range (bar)	Pressure increase (bar/turn)
KP000083	KPST-030-DPNA-HN-G12-N350	C1,V1 : G 1/2"	350	100-350	91
KP000084	KPST-030-DPNA-HN-G12-N200	C1,V1 : G 1/2"	200	50-210	42
KP000085	KPST-030-DPNA-HN-G12-N100	C1,V1 : G 1/2"	100	30-100	20
KP000086	KPST-030-DPNA-HN-G12-N050	C1,V1 : G 1/2"	50	5-50	10