

PILOT OPERATED CHECK VALVE

CDPN-060-PSNN

SEPARATE PILOT
POPPET TYPE

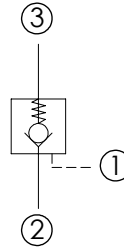
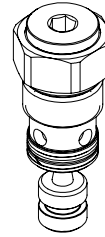
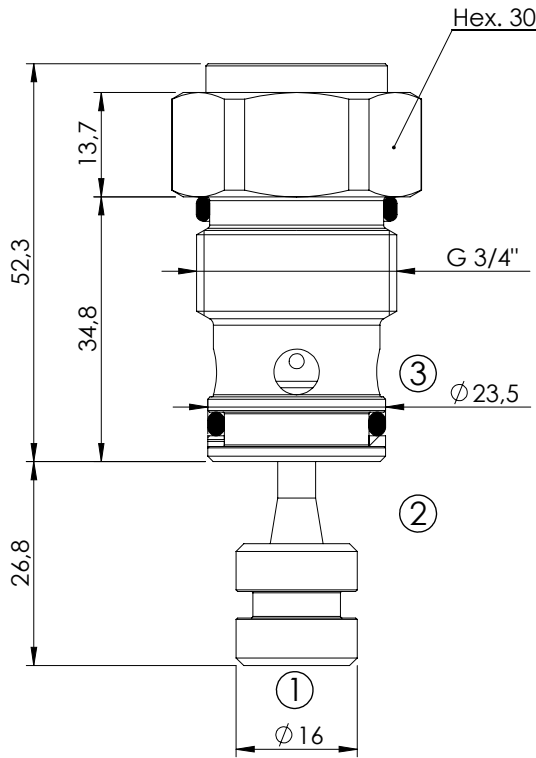

SPECIFICATIONS

Max. operating pressure:	350 bar
Rated flow:	60 l/min
Cavity:	VP000038
Weight:	0,2 kg
Pilot ratio:	3:1

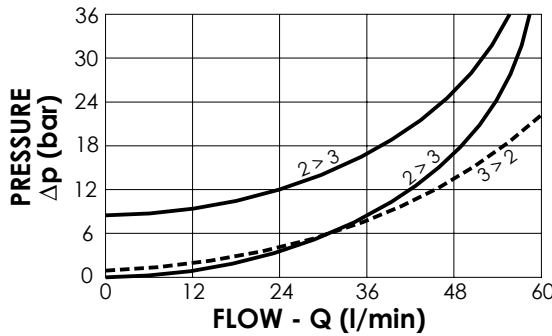

NOTES

Installation torque:	100 - 130 Nm
Seal kit:	RC700038

ORDERING CODES

Quick code	Description	Cracking pressure (bar)	O-Ring on pilot piston
SC000052	CDPN-060-PSNN-03-038-N001	1	NO
SC000054	CDPN-060-PSNN-03-038-N008	8	NO
SC000055	CDPN-060-PSNE-03-038-N008	8	YES