

PILOT OPERATED CHECK VALVE

MCDN-060-TLNS

DOUBLE ACTING

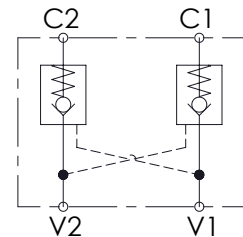
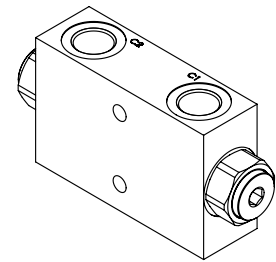
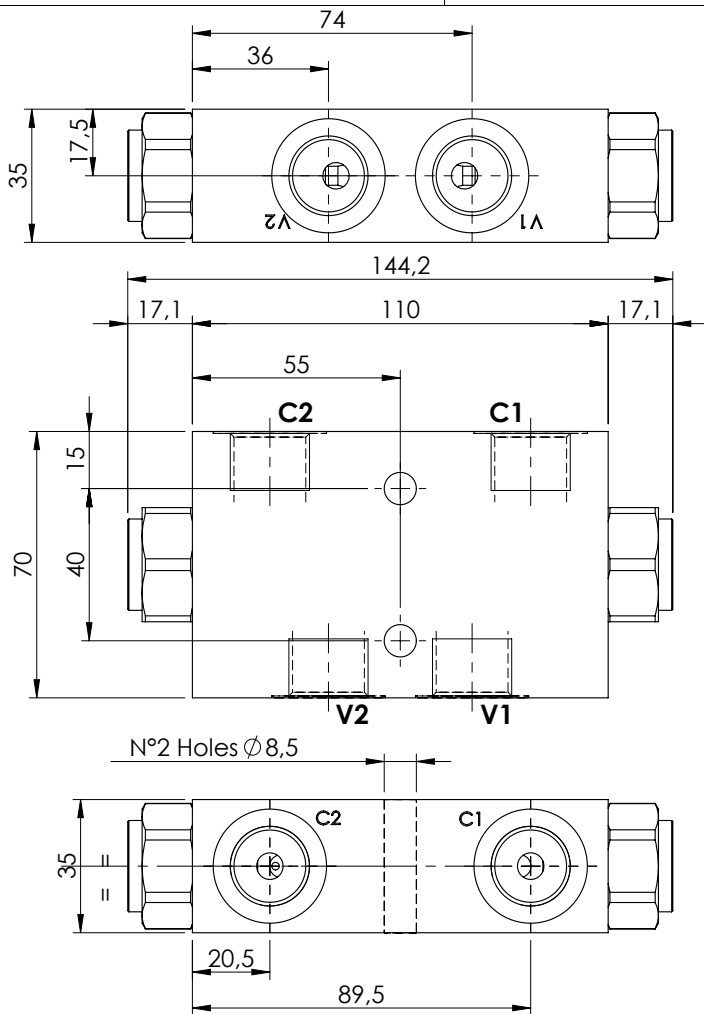

SPECIFICATIONS

Max. operating pressure:	350 bar
Rated flow:	60 l/min
Manifold:	Aluminium
Weight:	0,9 kg

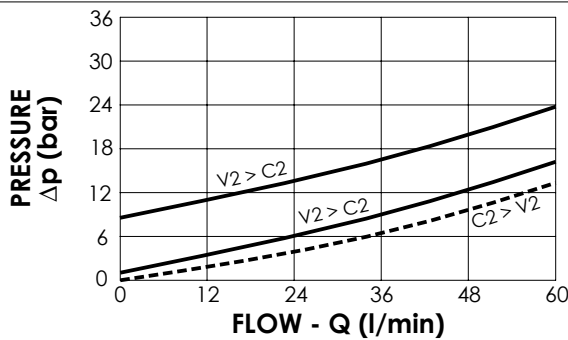

ORDERING CODES

Quick code	Description	Main ports size	Pilot ratio	Cracking pressure (bar)	O-Ring on pilot piston
MC000042	MCDN-060-TLNS-03-G12-N001	V1,V2,C1,C2 : G1/2"	3:1	1	NO
MC000040	MCDN-060-TLNS-03-G12-N008	V1,V2,C1,C2 : G1/2"	3:1	8	NO
MC000041	MCDN-060-TLNC-03-G12-N008	V1,V2,C1,C2 : G1/2"	3:1	8	YES