

REGENERATIVE VALVE

MRSN-150-ZLNV

REGENERATIVE

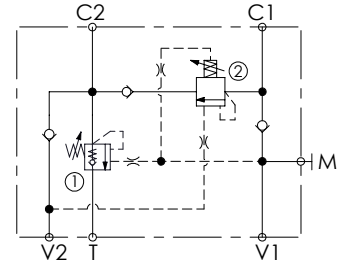
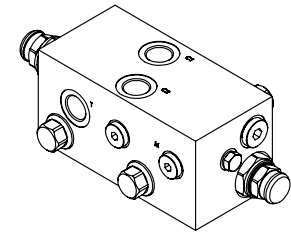
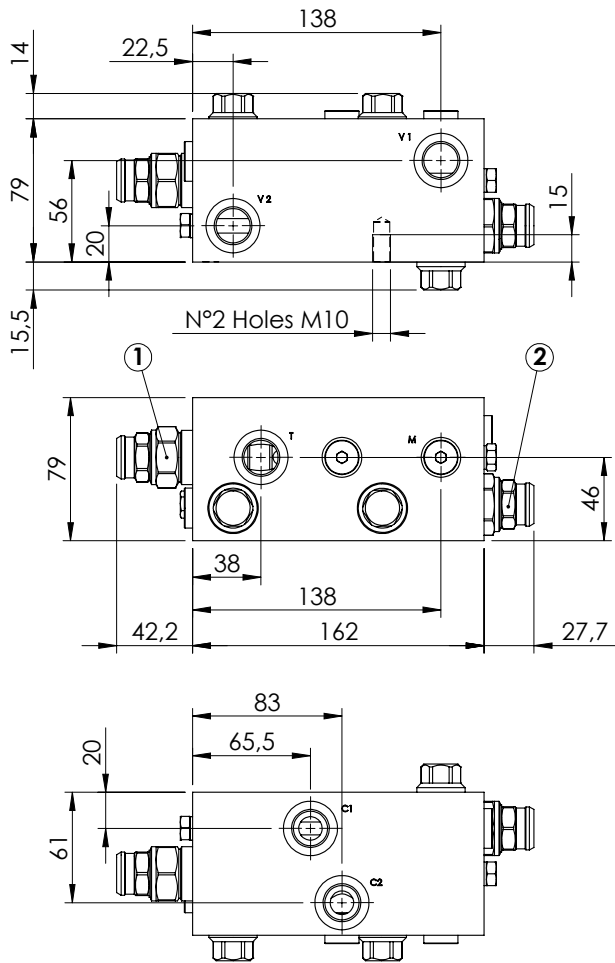

SPECIFICATIONS

Max. operating pressure:	350 bar
Rated flow:	150 l/min
Manifold:	Aluminium
Weight:	3,18 kg

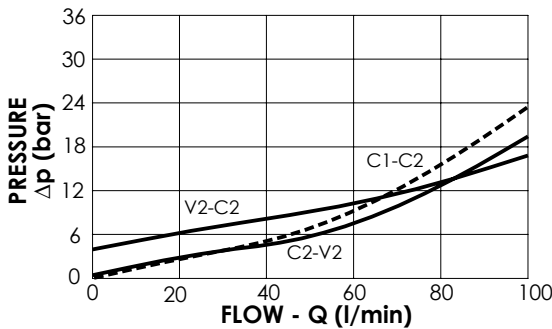

NOTES

Setting: at least 1.3 times the load induced pressure
 Designed for truck mounted cranes

ORDERING CODES

Quick code	Description	Pilot ratio	Main ports size	Standard setting (bar, Q=5 l/min)	Adjust. range (bar)	Pressure increase (bar/turn)
MB000113	MRSN-150-ZLNV-04-G12-N350	4:1	V1,V2,C1,C2,T : G1/2" M: G1/4"	350	100-350	104