

VALVES FOR MOTORS

MBDN-320-AMSR OVERCENTRE WITH BRAKE RELEASE

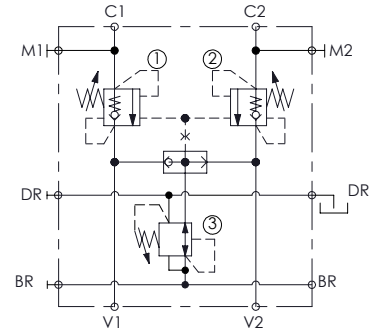
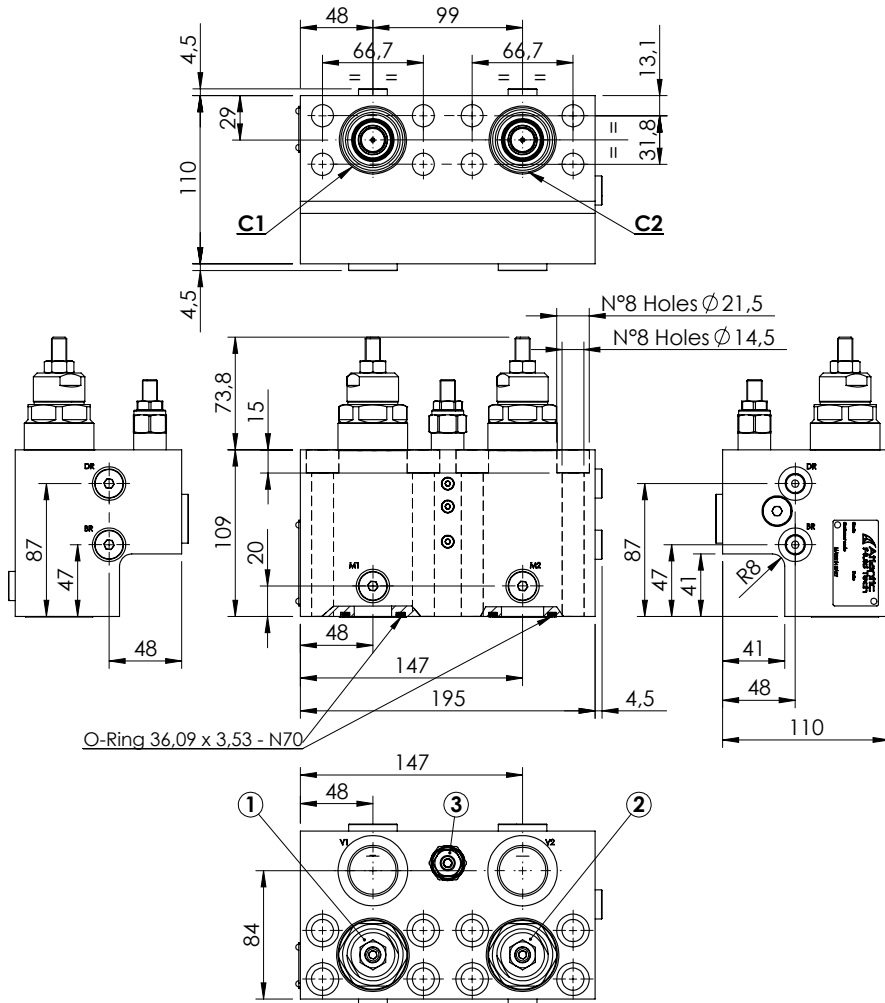
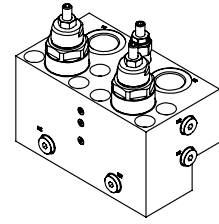

SPECIFICATIONS

Max. operating pressure:	350 bar
Rated flow:	320 l/min
Manifold:	Steel
Weight:	13,7 kg

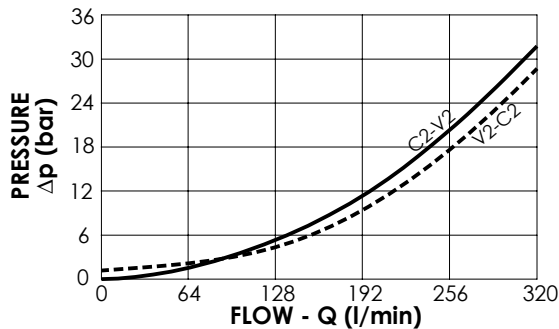

NOTES

Setting: at least 1.3 times the load induced pressure
 Designed for REXROTH A2FE 107-125 160-180 motors

ORDERING CODES

Quick code	Description	Pilot ratio	Main ports size	Standard setting (bar, Q=5 l/min)	Adjust. range (bar)	Pressure increase (bar/turn)
MB000563	MBDN-320-AMSR-08-S11-N350	8:1	V1,V2: G 1" C1,C2: 1-1/4" SAE 6000 BR,DR,M1,M2: G1/4"	①②: 350 ③: 40	①②: 140-350 ③: 10-60	①②: 56 ③: 6,5