

CHECK AND METERING VALVE

MLST-100-ALGL

IN LINE VERSION
LEFT VERSION

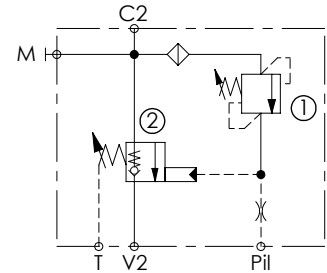
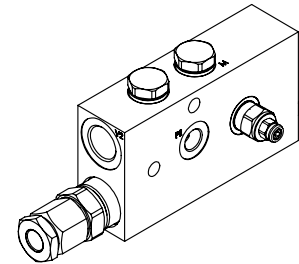
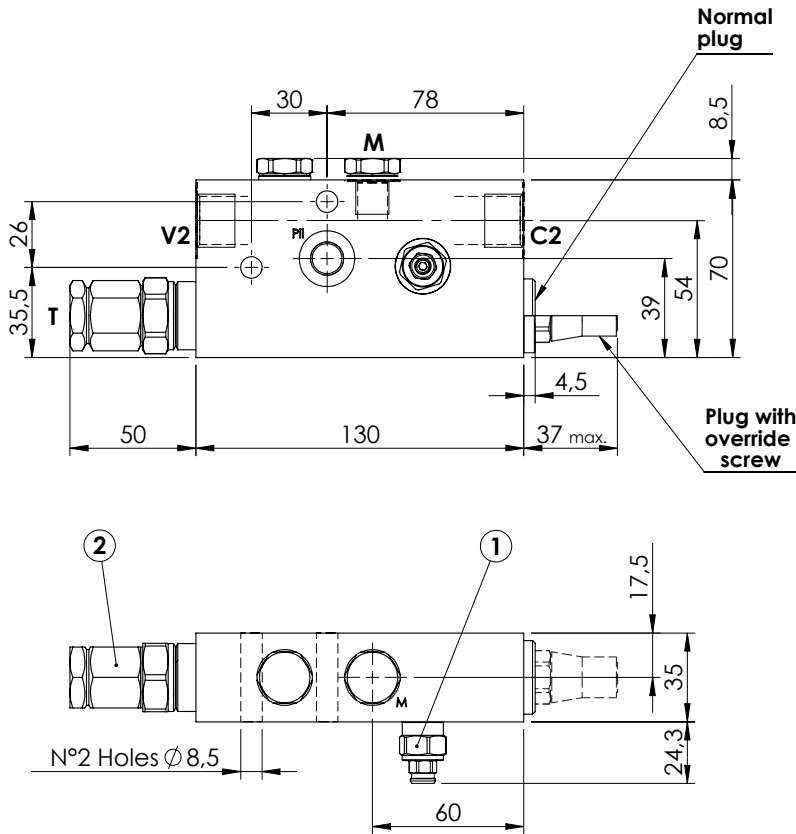

SPECIFICATIONS

Max. operating pressure:	420 bar
Rated flow:	100 l/min
Manifold:	Steel
Weight:	2,39 kg

NOTES

When correctly adjusted for the specific excavator installation, these valves meet the requirement of ISO 8643

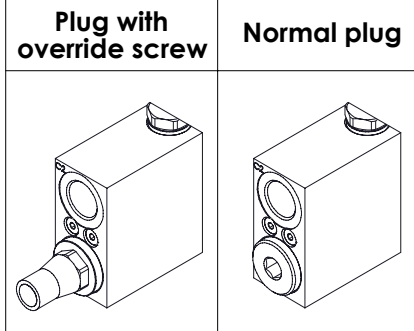
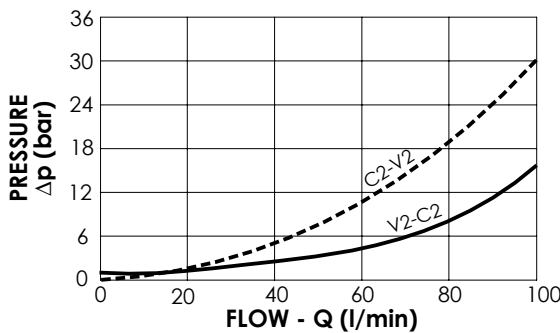

ORDERING CODES

Quick code	Description	Main ports size	Plug with override screw	Standard setting (bar)	Adjust. range (bar)	Pressure increase (bar/turn)
ML000136	MLST-100-ALGL-00-G12-N420	V2,C2: G 1/2" Pi, T, M: G 1/4"	No	① 350 Q=5 l/min ② 7.5 Crack. pr.	① 150-420 ② 3-15	① 236 ② 7
ML000149	MLST-100-ALGL-00-G12-E420	V2,C2: G 1/2" Pi, T, M: G 1/4"	Yes	① 350 Q=5 l/min ② 7.5 Crack. pr.	① 150-420 ② 3-15	① 236 ② 7
ML000137	MLST-100-ALGL-00-J12-N420	V2,C2: JIS 1/2" Pi, T, M: JIS 1/4"	No	① 350 Q=5 l/min ② 7.5 Crack. pr.	① 150-420 ② 3-15	① 236 ② 7
ML000150	MLST-100-ALGL-00-J12-E420	V2,C2: JIS 1/2" Pi, T, M: JIS 1/4"	Yes	① 350 Q=5 l/min ② 7.5 Crack. pr.	① 150-420 ② 3-15	① 236 ② 7