

CHECK AND METERING VALVE

MLST-700-AAGN

FLANGED TYPE
1" 1/2 SAE 6000

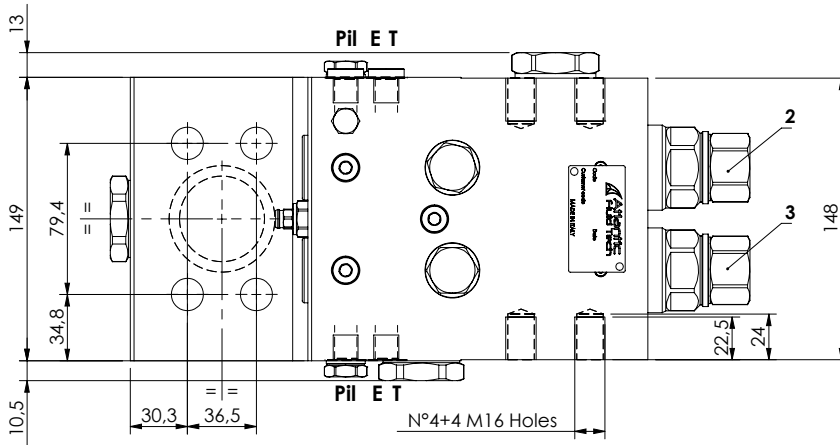
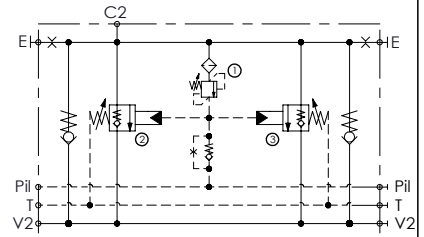
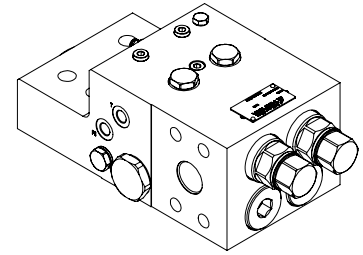
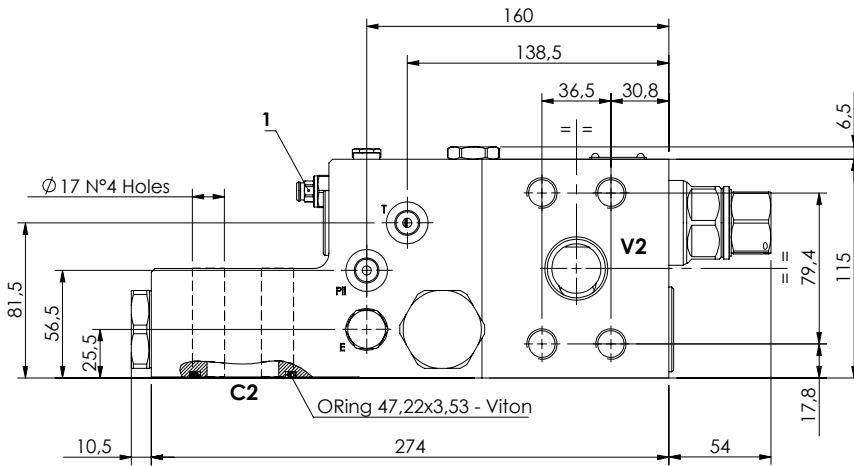

SPECIFICATIONS

Max. operating pressure:	420 bar
Rated flow:	700 l/min
Manifold:	Steel
Weight:	27,31 kg

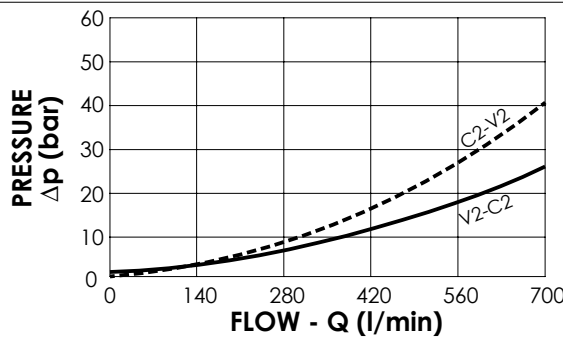

NOTES

When correctly adjusted for the special excavator installation, these valves meet the requirement of ISO 8643

ORDERING CODES

Quick code	Description	Main ports size	Standard setting (bar)	Adjust. range (bar)	Pressure increase (bar/turn)
ML000098	MLST-700-AAGN-00-S22-N420	V2,C2:1" 1/2 SAE 6000 E,Pil,T:G 1/4"	① 400 Q=5 l/min ②③ 7.5 Crack. pr.	① 150-420 ②③ 3-15	① 236 ②③ 3.4
ML000094	MLST-700-AAJN-00-S22-N420	V2,C2:1" 1/2 SAE 6000 E,Pil,T:1/4" JIS	① 400 Q=5 l/min ②③ 7.5 Crack. pr.	① 150-420 ②③ 3-15	① 236 ②③ 3.4