

CHECK AND METERING VALVE

**MLST-1400-AAGL**

FLANGED TYPE  
2" SAE 6000  
LEFT VERSION

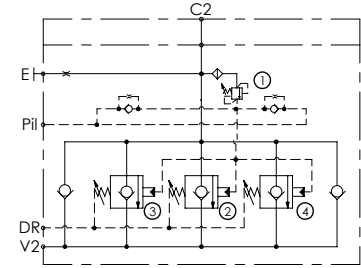
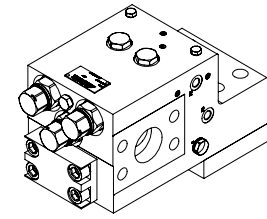
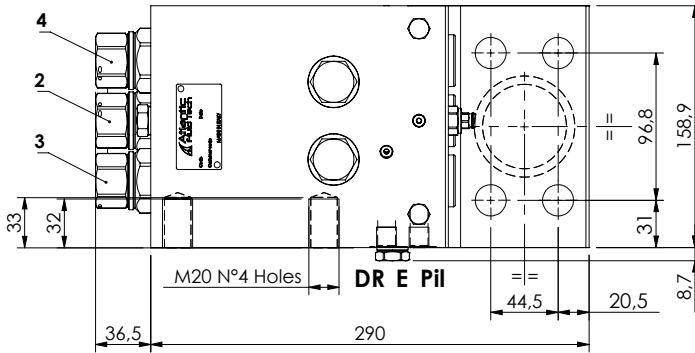
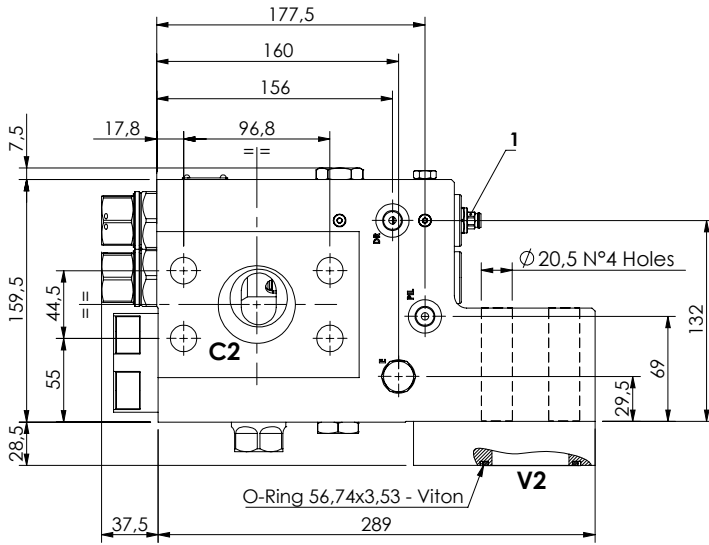

**SPECIFICATIONS**

Max. operating pressure:	420 bar
Rated flow:	1400 l/min
Manifold:	Steel
Weight:	45,86 kg

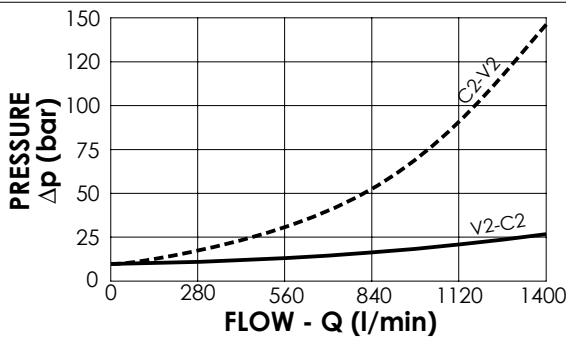

**NOTES**

When correctly adjusted for the special excavator installation, these valves meet the requirement of ISO 8643

**ORDERING CODES**

Quick code	Description	Main ports size	Standard setting (bar)	Adjust. range (bar)	Pressure increase (bar/turn)
ML000166	MLST-1400-AAGL-00-S20-N420	V2,C2:2" SAE 6000 E,Pil,T:G 1/4"	①400 Q=5 l/min ②③④7,5 Crack. pr.	①150-420 ②③④3-15	①236 ②③④3.4