

**FLOW REGULATOR**

**MFCT-055-RVTR**

**3 WAYS COMPENSATED**

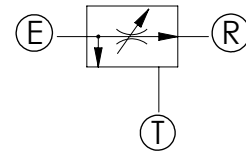
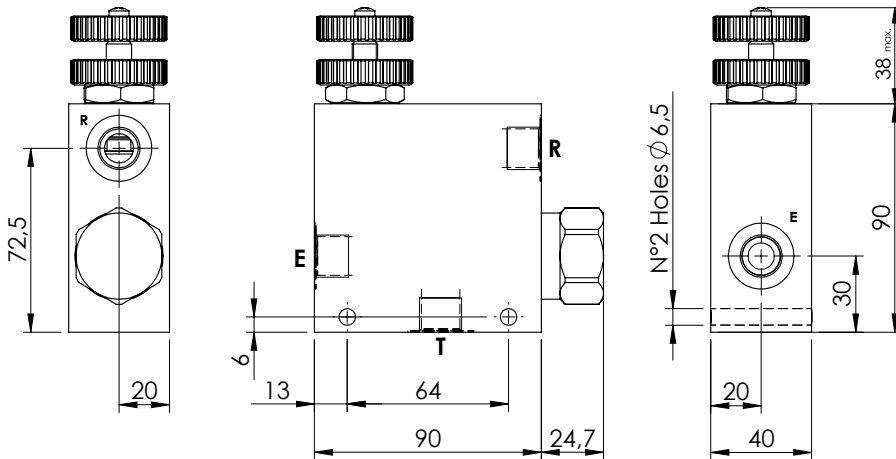
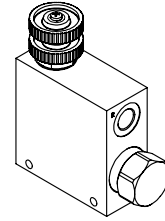
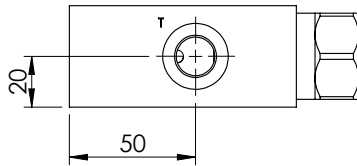

**SPECIFICATIONS**

Max. operating pressure:	see table
Rated flow:	55 l/min
Manifold:	Aluminium/Steel
Weight:	1,12/2,48 kg

**ADJUSTMENT OPTIONS**



**NOTES**

Regulation sensitivity: FINE

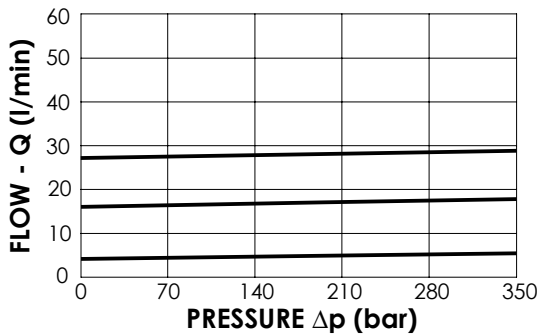

**ORDERING CODES**

Quick code	Description	Main ports size	Manifold	Max. Pressure (Bar)	Max. reg.flow (l/min)	Max. inlet flow (l/min)	Adjustment options
MF000008	MFCT-055-RVTR-30-G38-N210	G 3/8"	Aluminium	210	30	55	Handknob and locknut
MF000009	MFCT-055-RHTR-30-G38-N210	G 3/8"	Aluminium	210	30	55	Screw and locknut
MF000010	MFCT-055-RMTR-30-G38-N210	G 3/8"	Aluminium	210	30	55	Graduated handknob
MF000089	MFCT-055-RVSR-30-G38-N350	G 3/8"	Steel	350	30	55	Handknob and locknut
MF000090	MFCT-055-RHSR-30-G38-N350	G 3/8"	Steel	350	30	55	Screw and locknut
MF000091	MFCT-055-RMSR-30-G38-N350	G 3/8"	Steel	350	30	55	Graduated handknob