

**FLOW REGULATOR**

**MFCT-150-RVTR**

**3 WAYS COMPENSATED**

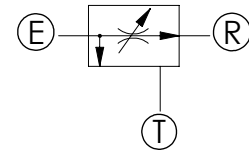
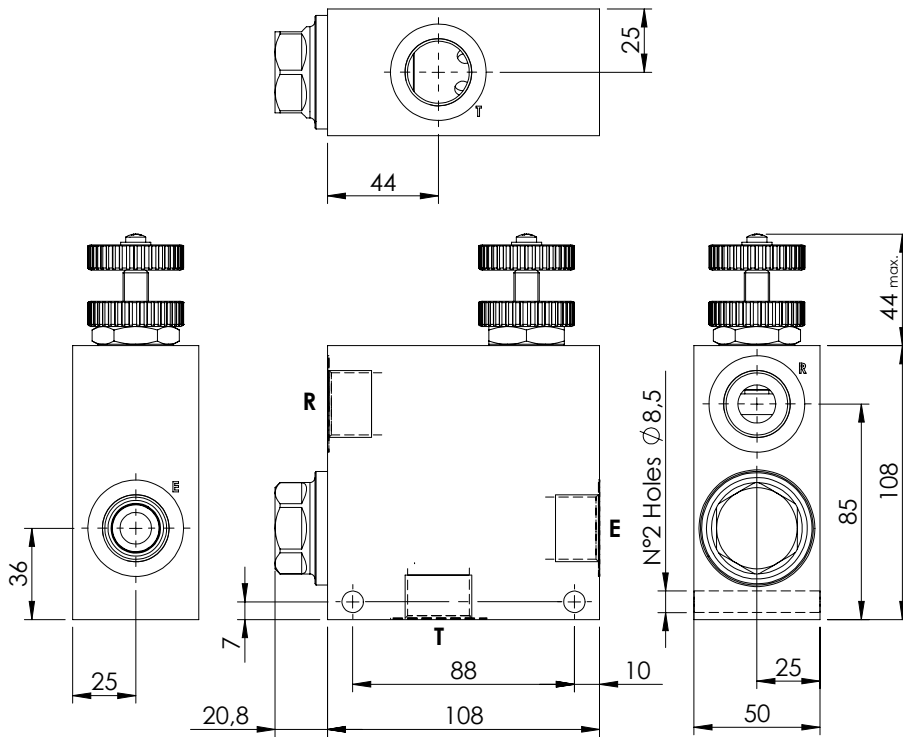
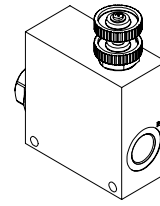

**SPECIFICATIONS**

Max. operating pressure:	see table
Rated flow:	150 l/min
Manifold:	Aluminium/Steel
Weight:	1,79/4,23 kg

**ADJUSTMENT OPTIONS**

Handknob and locknut	Screw and locknut	Graduated handknob

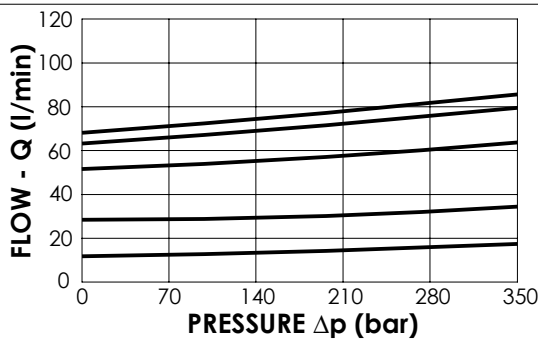

**NOTES**

Regulation: STANDARD

**ORDERING CODES**

Quick code	Description	Main ports size	Manifold	Max. Pressure (Bar)	Max. reg.flow (l/min)	Max. inlet flow (l/min)	Adjustment options
MF000031	MFCT-150-RVTR-90-G34-N210	G 3/4"	Aluminium	210	90	150	Handknob and locknut
MF000032	MFCT-150-RHTR-90-G34-N210	G 3/4"	Aluminium	210	90	150	Screw and locknut
MF000033	MFCT-150-RMTR-90-G34-N210	G 3/4"	Aluminium	210	90	150	Graduated handknob
MF000023	MFCT-150-RVSR-90-G34-N350	G 3/4"	Steel	350	90	150	Handknob and locknut
MF000024	MFCT-150-RHSR-90-G34-N350	G 3/4"	Steel	350	90	150	Screw and locknut
MF000025	MFCT-150-RMSR-90-G34-N350	G 3/4"	Steel	350	90	150	Graduated handknob