

ALL TERRAIN CRANES

MLST-250-AAGN

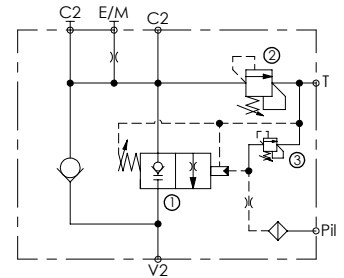
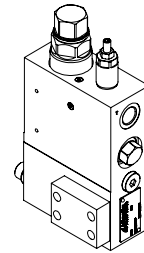
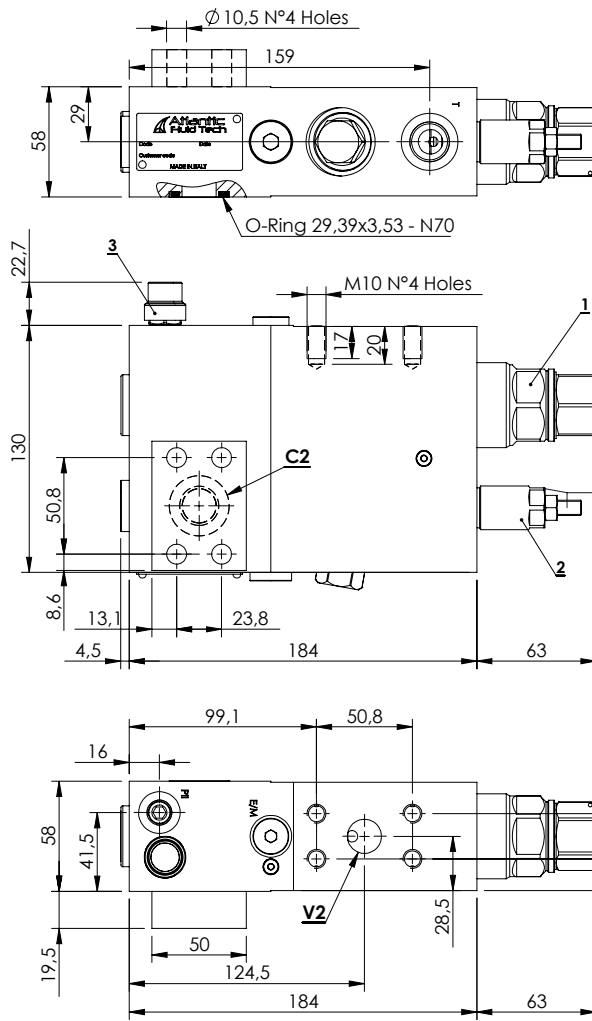

SPECIFICATIONS

Max. operating pressure:	350 bar
Rated flow:	250 l/min
Manifold:	Steel
Weight:	10,54 kg

SEALING CAP

Ordering code:
AT000020

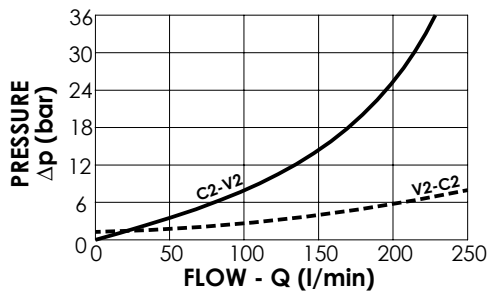
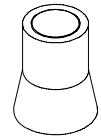

NOTES

When correctly adjusted for the special excavator installation, these valves meet the requirement of ISO 8643

Piston with grooves

ORDERING CODES

Quick code	Description	Main ports size	Standard setting (bar)	Adjust. range (bar)	Pressure increase (bar/turn)
ML000212	MLST-250-AAGN-00-S34-N350	V2,C2: 3/4" SAE 6000 E/M,Pil: G 1/4" T: G 1/2"	① 9 Q=5 l/min ③ 20 C.P. ② 350 Q=5 l/min	① 2-15 ③ 10-40 ② 100-350	① 1,6 ③ 22 ② 91