

CONCRETE PUMP CRANES

**MBSN-060-ZAPF**

SINGLE ACTING  
FLANGED

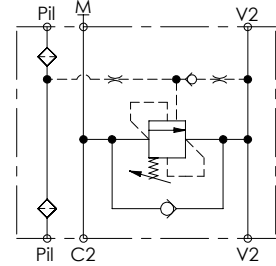
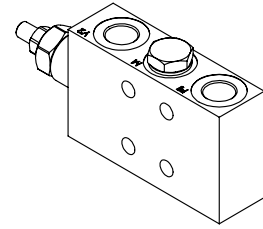
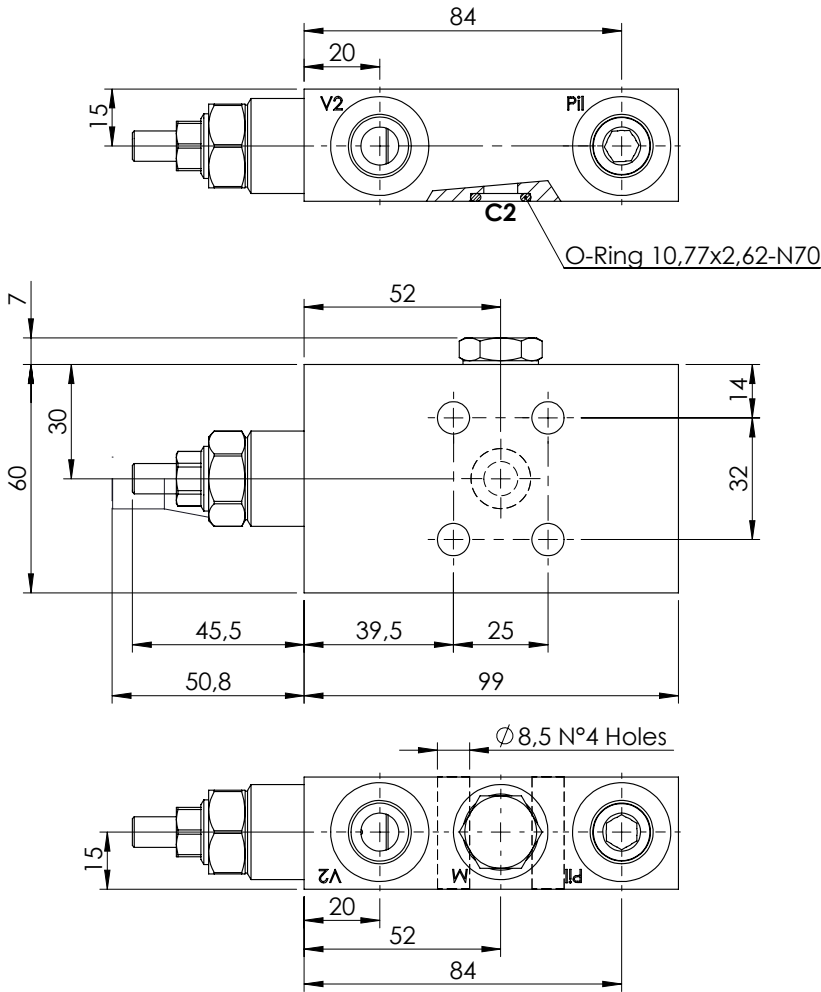

**SPECIFICATIONS**

Max. operating pressure:	350 bar
Rated flow:	60 l/min
Manifold:	Aluminium
Weight:	0,56 kg

**SEALING CAP**

Ordering code:  
AT000020

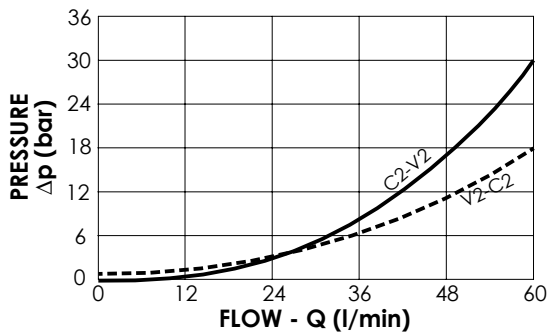
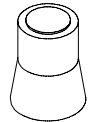

**NOTES**

Setting: at least 1.3 times the load induced pressure

Pilot ratio: 4,2:1  
Operative pilot ratio: 2,1:1

**ORDERING CODES**

Quick code	Description	Main ports size	Standard setting (bar, Q=5 l/min)	Adjust. range (bar)	Pressure increase (bar/turn)
MB000461	MBSN-060-ZAPF-02-G38-N350	V2,P11:G 3/8" M:M12x1,5	340	100-350	138