

HOOK LOADERS

**MRSN-150-ALBE**

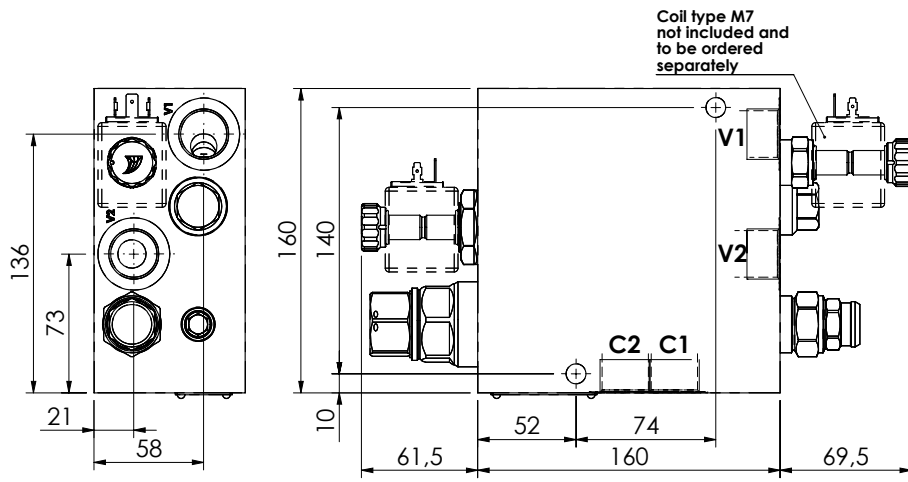
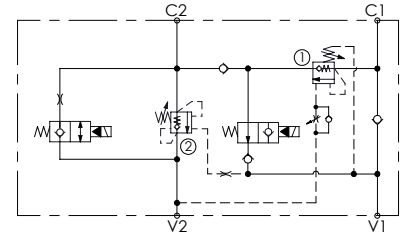
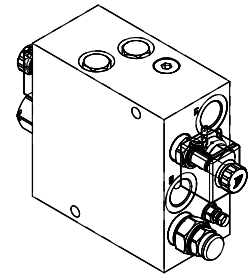
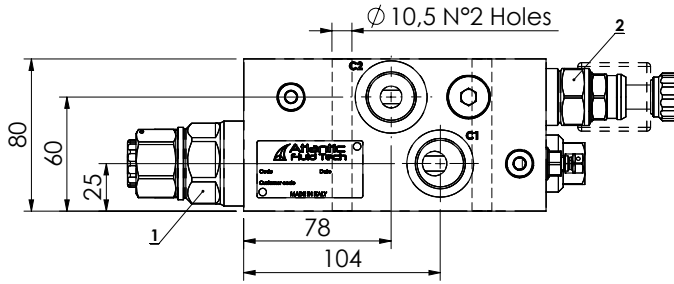

**SPECIFICATIONS**

Max. operating pressure:	350 bar
Rated flow:	150 l/min
Manifold:	Steel
Weight:	14,95 kg
Coil type:	M7

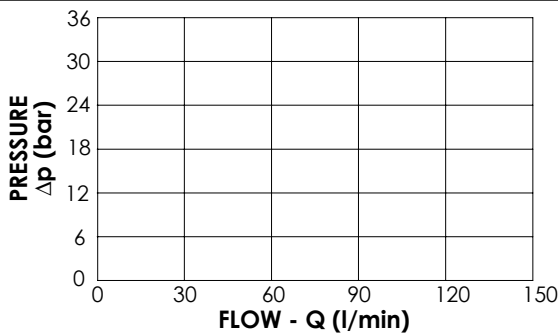

**NOTES**

Seating: at least 1.3 times the load induced pressure

**ORDERING CODES**

Quick code	Description	Pilot ratio	Main ports size	Standard setting (bar, Q=5 l/min)	Adjust. range (bar)	Pressure increase (bar/turn)
MB000920	MRSN-150-ALBE-04-G34-N350	4:1	V1, V2: G3/4" C1, C2: G3/4"	350	100-350	104