

COIL

# COIL SERIES M11

DIN 43650 - ISO 4400  
CLASS H

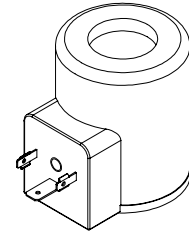
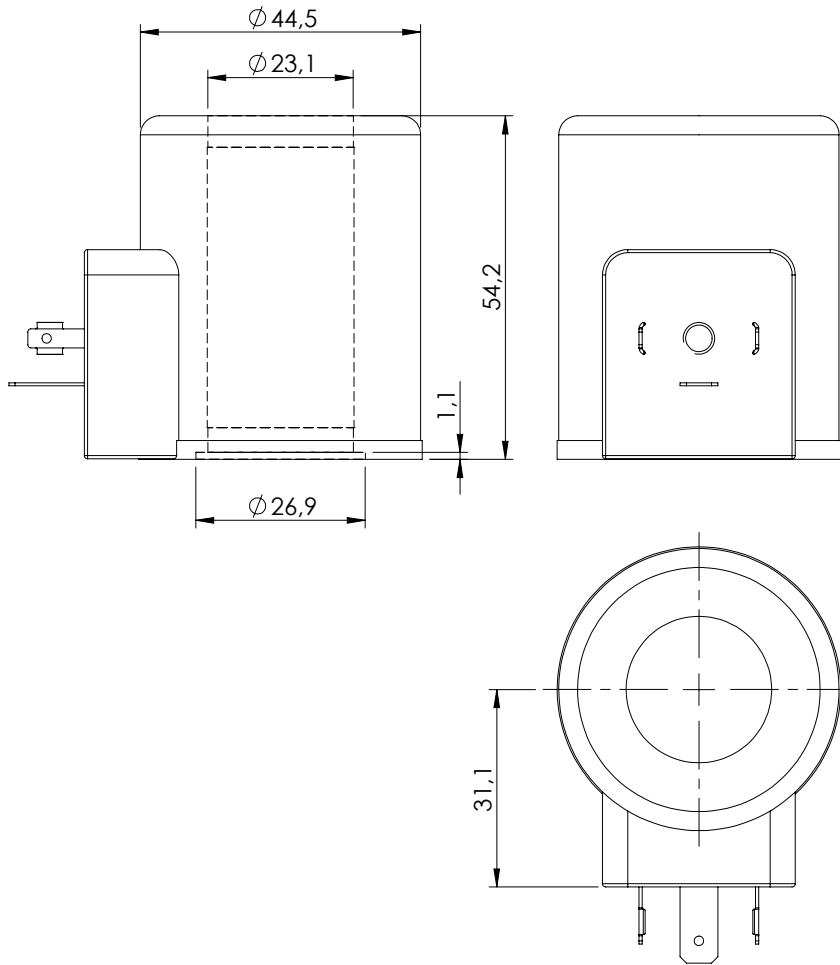

## SPECIFICATIONS

Heat insulation class H	180°C
Ambient temperature	-20 + 50°C
Inlet voltage	±10% tol.
Insulation class IP65 with all seals properly mounted	
Weight:	0,350 kg

## NOTES

## ORDERING CODES

Quick code	Description	Connection type	Voltage (V)	Resistance ( $\Omega$ ) $\pm 7\%$	Power (w)	Current (A)
AB000149	Coil M11 HS 12V CLASS H	DIN 43650-ISO 4400	12 DC	3.27	44	3.67
AB000150	Coil M11 HS 24V CLASS H	DIN 43650-ISO 4400	24 DC	13.09	44	1.83